

Ordering Code: **7GKX1C001** **162A-2 Cavity to 8A-2 Cavity Converter**

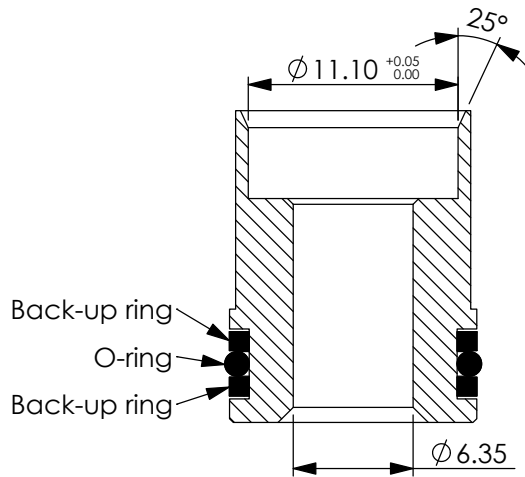

**\* Ordering Code: 7GKX1C001**

Illustrations / detail are for reference only. Data subject to change.

The cavity of 162A-2 can be converted to 8A-2 by sleeve 7GKX1C001. For example: The valve of PRB-8A-2D can assemble with the cavity of 162A-2.

**\* Please note the upper size of locating shoulder of cavity for correct assembly.**

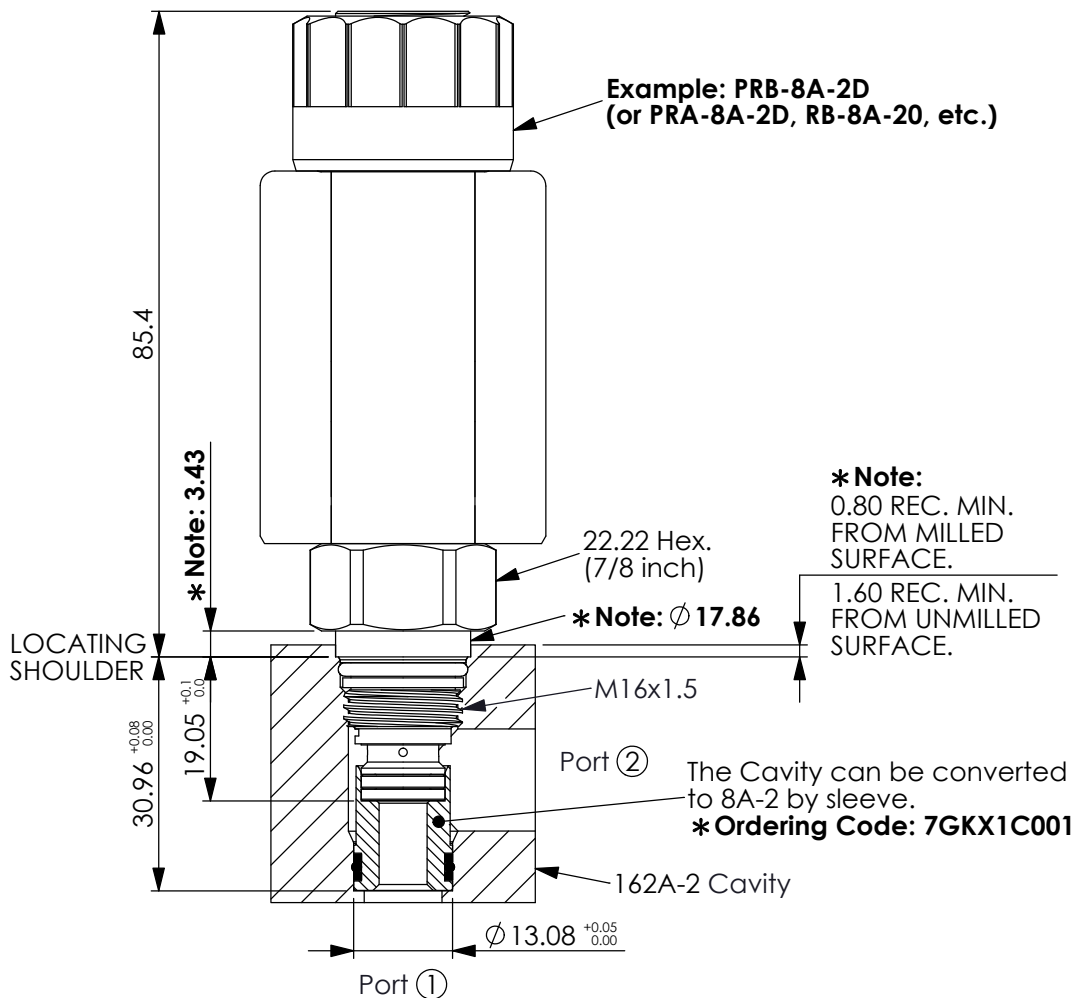

UNIT:mm

Illustrations / detail are for reference only. Data subject to change.