

COUNTERBALANCE VALVE (Vented, Atmospherically Referenced, 280 Bar Maximum Setting)

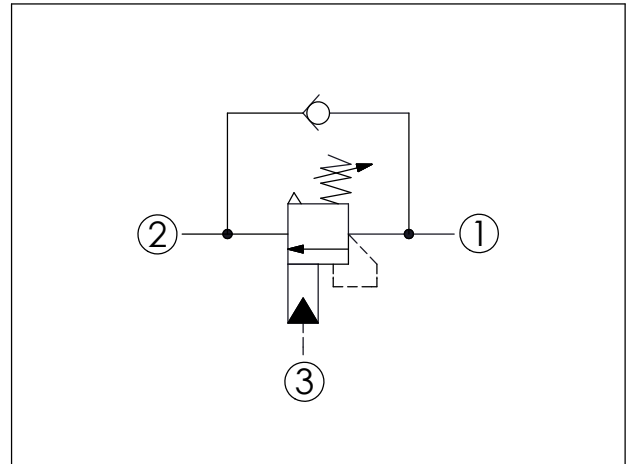

TECHNICAL DATA		
Max. Setting:	280	bar
Rated flow:	240	l/min
Cavity-Tooling:	17A-3	
Installation torque:	200 - 215	Nm
Weight:	0.74	kg
<ul style="list-style-type: none"> Pressure Setting: Setting should be 1.3 times maximum load induced pressure. (We suggest when the Max. setting pressure is 280 bar, the load pressure has to be lower than 215 bar.) Approximately 1 drop (0.07 cc) of fluid will pass from the pilot area to the vented spring chamber every 4000 cycles. 		

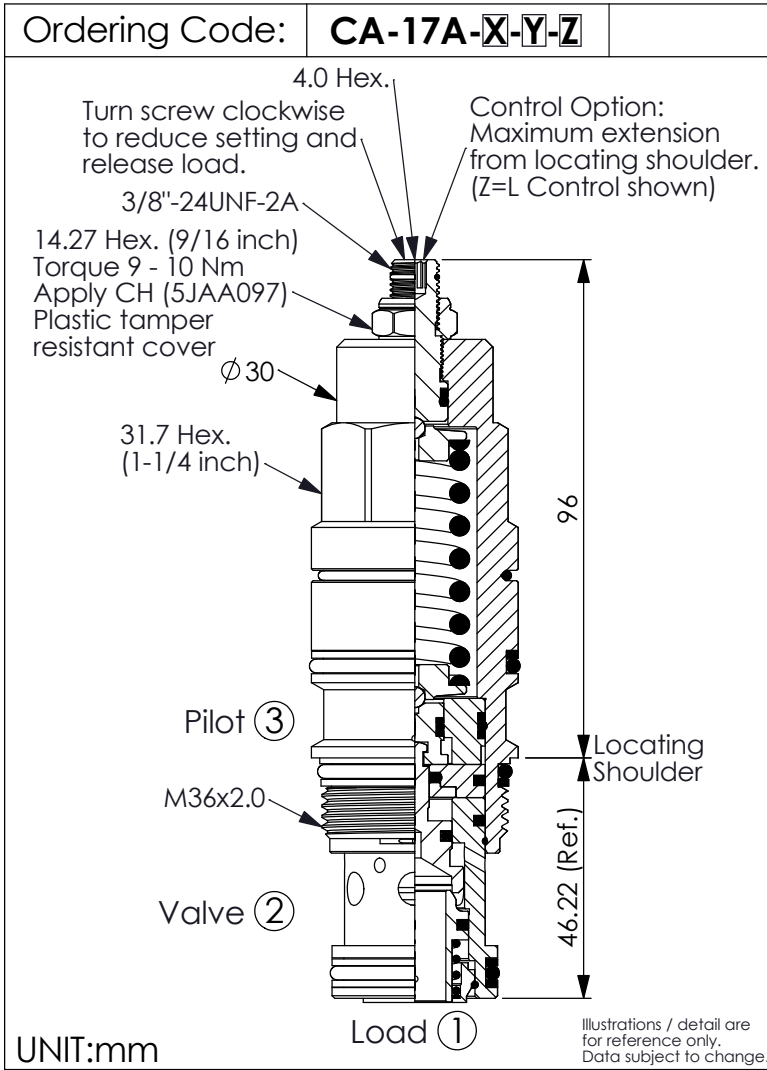
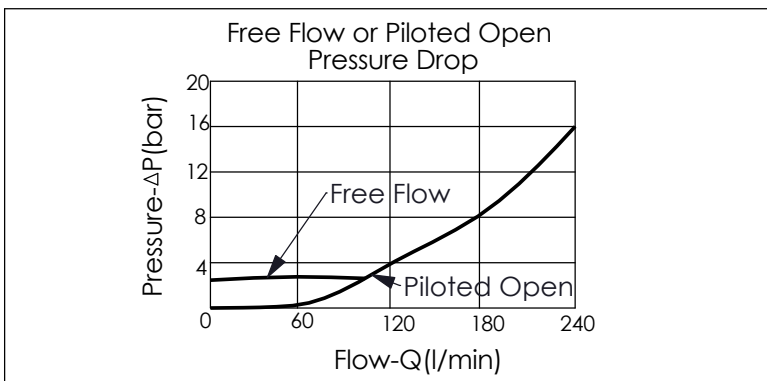

X	PILOT RATIO	
3A	1 : 1 (with sealed pilot)	
3C	3 : 1 (with sealed pilot)	

Y	SPRINGS	
	ADJUSTMENT RANGES (1.7 bar Cracking Pressure)	
H	70 - 280 bar	(210 bar Standard Setting)
I	25 - 105 bar	(70 bar Standard Setting)

Z	OPTIONS	
L	Leakproof hex. socket screw.	
C	Stainless Steel Tamper Resistant Cover.	
CH	Plastic Tamper Resistant Cover of General Type Hex. Nut (Order Code:5JAA097)	