

COUNTERBALANCE VALVE (Ultra-Restrictive, 350 Bar Maximum Setting)

Ordering Code: **CB-11A-X-Y-Z10**

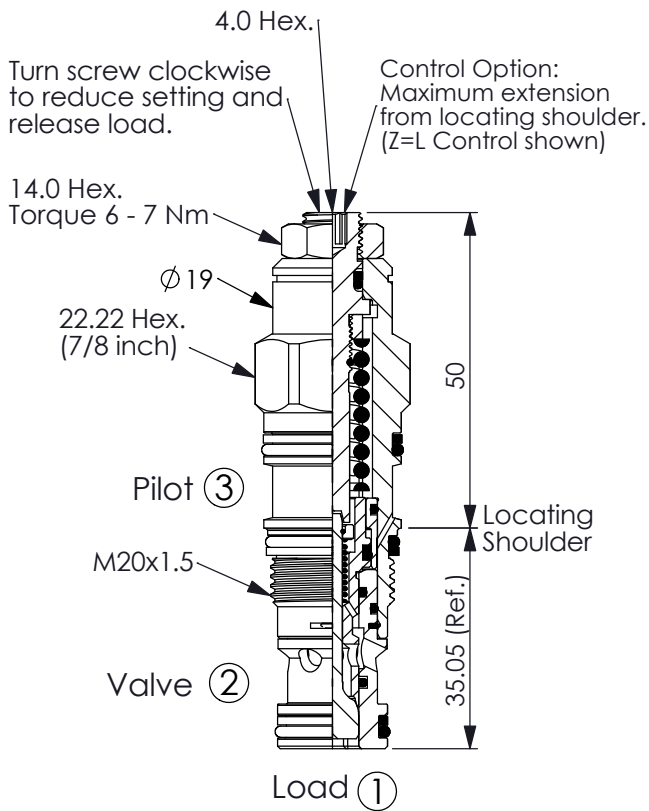

UNIT:mm

Illustrations / detail are for reference only. Data subject to change.

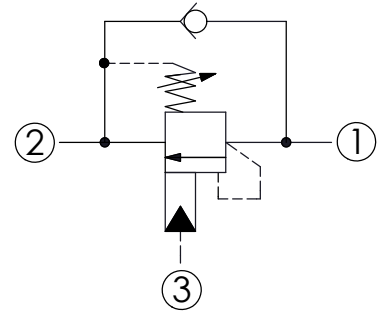

TECHNICAL DATA

Max. Setting:	350	bar
Rated flow:	10 l/min From Port ① to ②	60 l/min From Port ② to ①
Cavity-Tooling:	11A-3	
Installation torque:	40 - 50	Nm
Weight:	0.151 (Z=L) kg	

Pressure Setting:

Setting should be 1.3 times maximum load induced pressure. (We suggest when the Max. setting pressure is 350 bar, the load pressure has to be lower than 270 bar.)

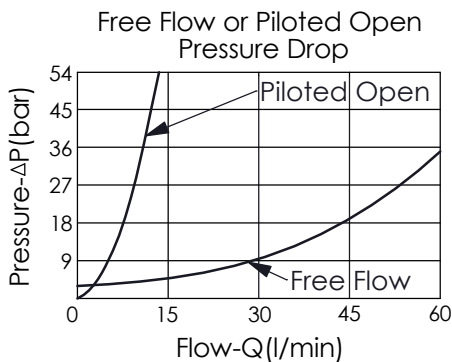

X	PILOT RATIO	
3D	4.5 : 1	(with sealed pilot)
3J	10 : 1	(with sealed pilot)

Y	SPRINGS	
	ADJUSTMENT RANGES(1.7 bar Cracking Pressure)	
J	140 - 350 bar	(210 bar Standard Setting)
K	70 - 175 bar	(140 bar Standard Setting)
	SPECIAL PURPOSES(0.3 bar Cracking Pressure)	
C	140 - 350 bar	(210 bar Standard Setting)
D	70 - 175 bar	(140 bar Standard Setting)

Z	OPTIONS	
L	Leakproof hex. socket screw.	
LP	Leakproof hex. socket screw. With stainless steel external metal components	
CA	Plastic Tamper Resistant Cover (Order Code:5JAA094)	