

Ordering Code: **CO-08W-X-Y-Z**

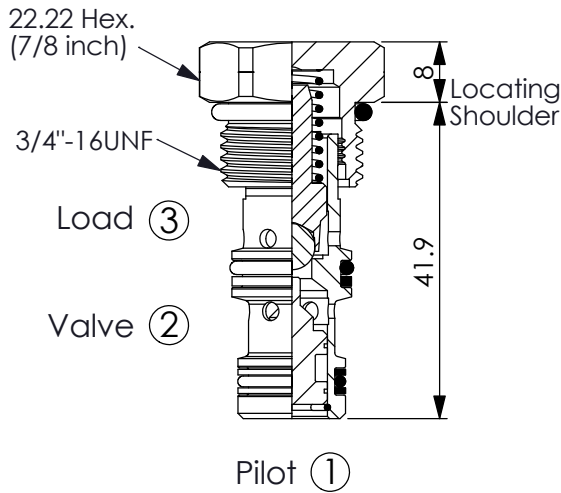

UNIT:mm

Illustrations / detail are for reference only. Data subject to change.

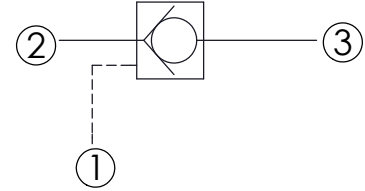

TECHNICAL DATA

Max. pressure:	240	bar
Rated flow:	30	l/min
Cavity-Tooling:	08W-3	
Installation torque:	25 - 35	Nm
Weight:	0.06	kg

Typical Pressure Drop

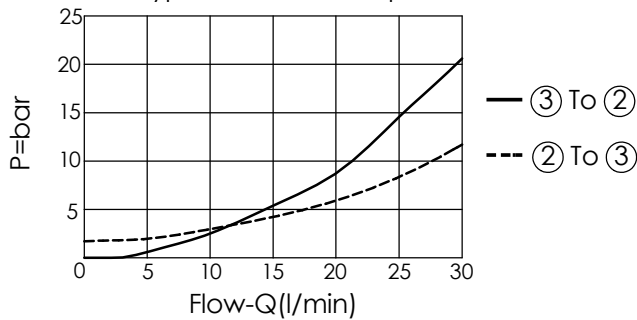

X OPERATION

33	② to ③ (Free Flow) Pilot Ratio 3:1
3C	② to ③ (Free Flow) Sealed Pilot Piston Pilot Ratio 3:1 (Check Spring Bias) (Min. 4.8 bar)

Y

SPRINGS

Cracking pressure

17	1.7 bar
48	4.8 bar
62	6.2 bar
82	8.2 bar

Z

OPTION

N Non-adjustable