

Ordering Code: **CV-10W-X-Y-Z-2**

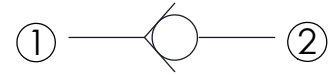
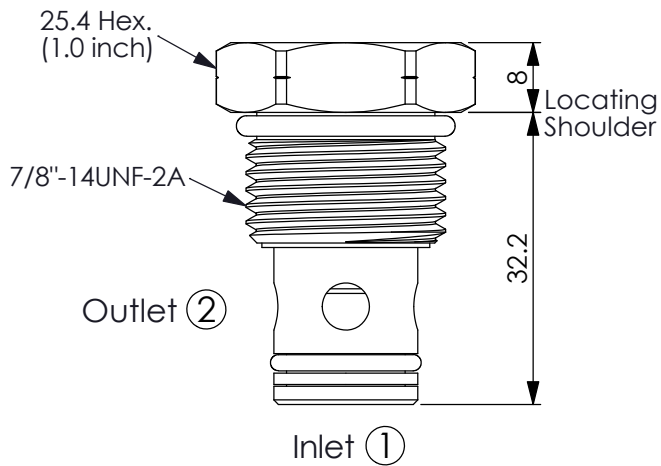

TECHNICAL DATA

Max. pressure:	350	bar
Rated flow:	60	l/min
Cavity-Tooling:	10W-2	
Installation torque:	35 - 40	Nm
Weight:	0.08	kg

UNIT:mm

Illustrations / detail are for reference only. Data subject to change.

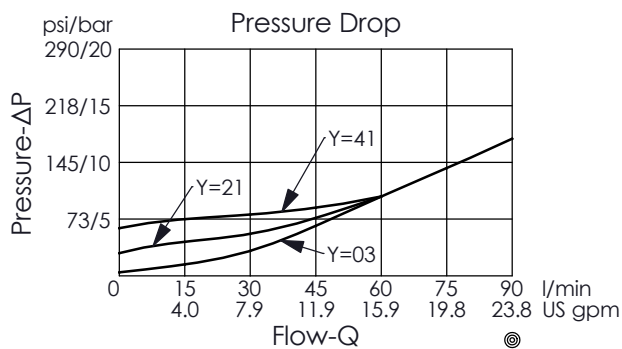

X OPERATION

20 ① to ② (Free Flow)

Y SPRINGS

Cracking pressure

03	0.3 bar
07	0.7 bar
17	1.7 bar
21	2.1 bar
41	4.1 bar
69	6.9 bar

Z OPTION

N Non-adjustable