

Ordering Code: **CV-12W-X-Y-Z**

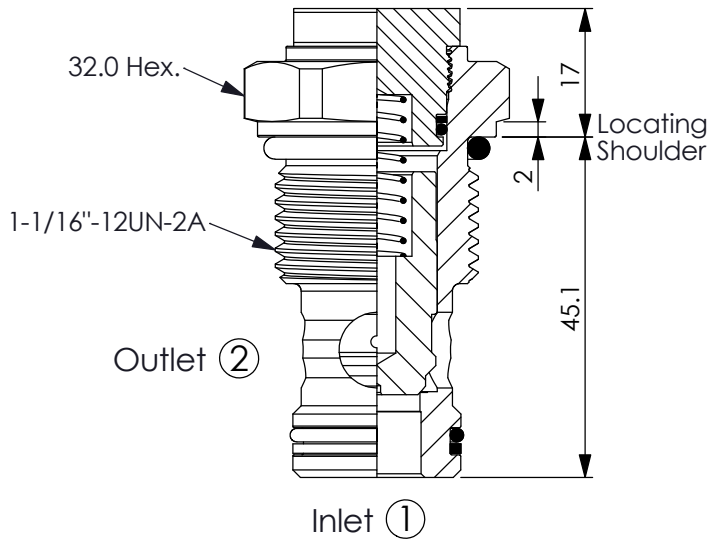

UNIT:mm

Illustrations / detail are for reference only. Data subject to change.

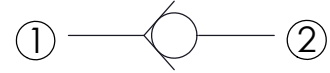

TECHNICAL DATA

Rated pressure:	350	bar
(Max. pressure:	420	bar)
Rated flow:	100	l/min
Cavity-Tooling:	12W-2	
Installation torque:	45 - 55	Nm
Weight:	0.20	kg

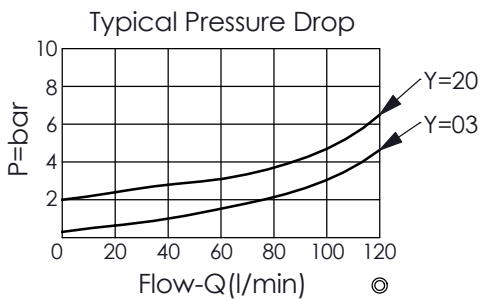

X OPERATION

22 ① to ② (Free Flow)

Y SPRINGS

Cracking pressure

03	0.3 bar
10	1.0 bar
20	2.0 bar
50	5.0 bar

Z OPTION

N Non-adjustable