

Ordering Code: **CV-17A-X-Y-Z**

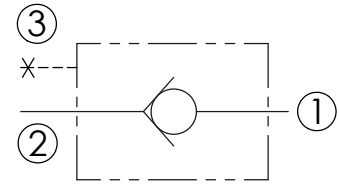
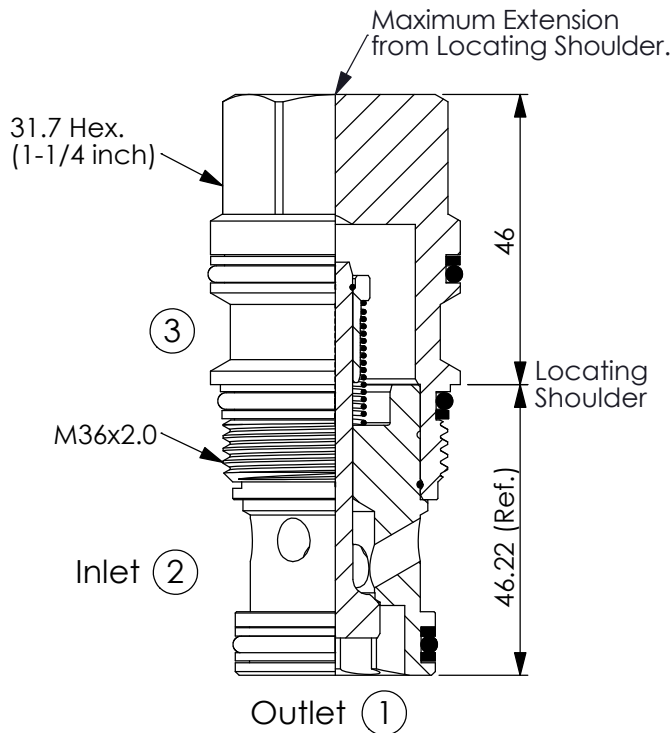

TECHNICAL DATA

Max. Operating pressure:	350	bar
Rated flow:	240	l/min
Cavity-Tooling:	17A-3	
Installation torque:	200 - 215	Nm
Weight:	0.48	kg

UNIT:mm

Illustrations / detail are for reference only. Data subject to change.

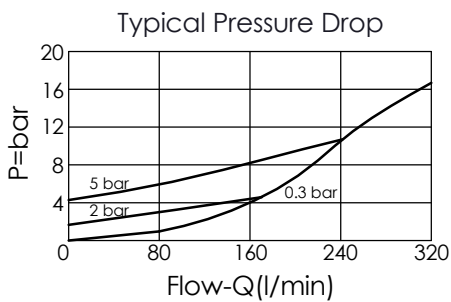

X OPERATION

21 ② to ① (Free Flow)

Y

SPRINGS

Cracking pressure

015	0.15 bar
03	0.3 bar
10	1.0 bar
20	2.0 bar
35	3.5 bar
50	5.0 bar
70	7.0 bar

Z OPTION

N	Non-adjustable	
NP	Non-adjustable With stainless steel external metal components (Buna-N Seal)	