

DIRECTIONAL VALVE (4-Way, 3-Position Spool, Pilot-to-shift)

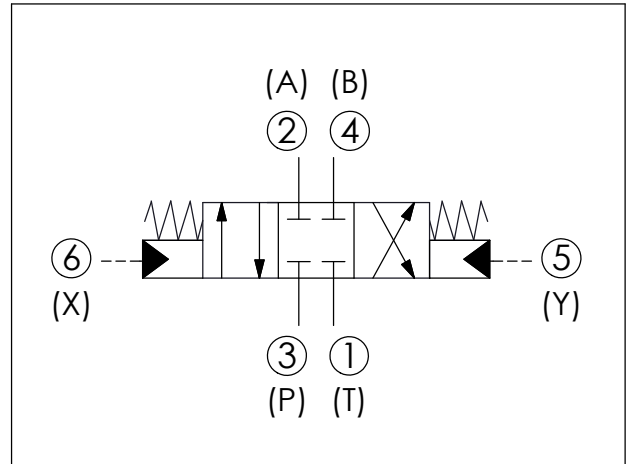
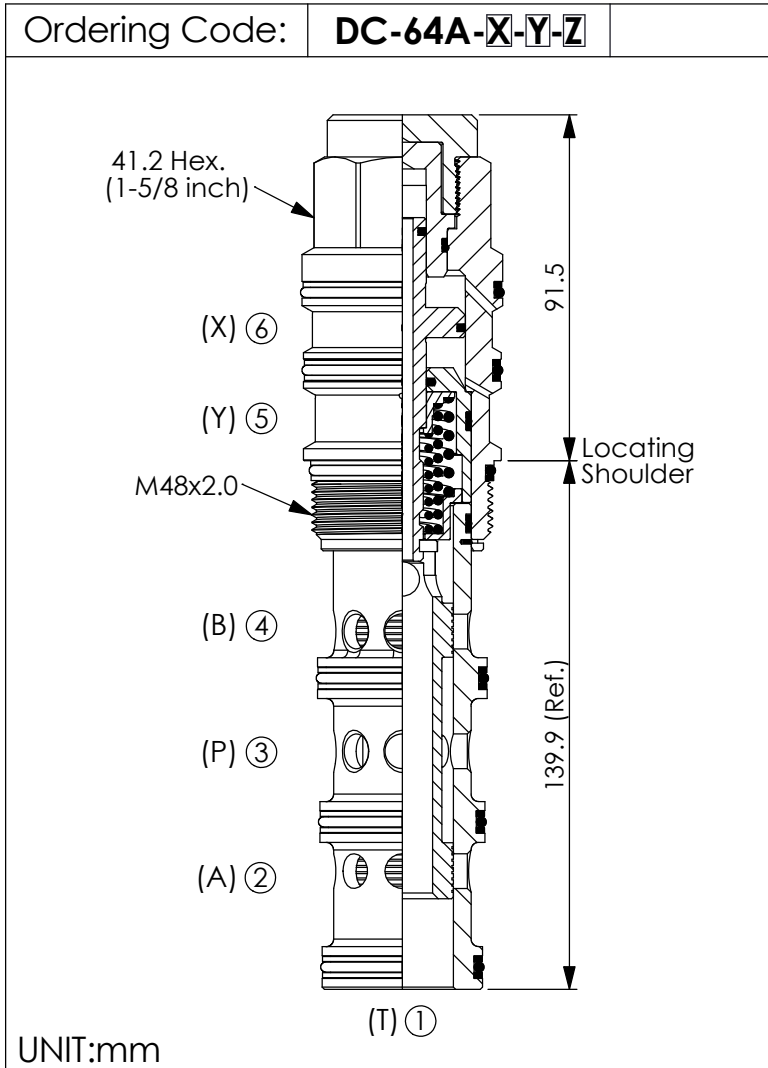

TECHNICAL DATA

Max. pressure:	350	bar
Rated flow:	200 - 760	l/min (Refer To Performance Chart)
Cavity-Tooling:	64A-6	
Installation torque:	465 - 500	Nm
Weight:	1.98	kg
<ul style="list-style-type: none"> • Minimum Pilot Pressure Required to Shift Valve : 9 bar. • Maximum Leakage Approximately (30 cc/min./70 bar) • All ports will accept 350 bar. 		

Performance Chart

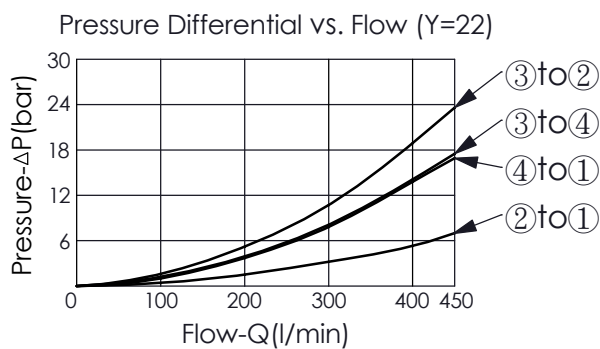

X OPERATION

6E Pilot-to-shift

Y SPOOL CONFIGURATION

22 Spool 4-Way, 3-Position,
Blocked Centre

Z OPTIONS

N Non-adjustable