

DIRECTIONAL VALVE (4-Way, 2-Position Spool, Pilot-to-shift)

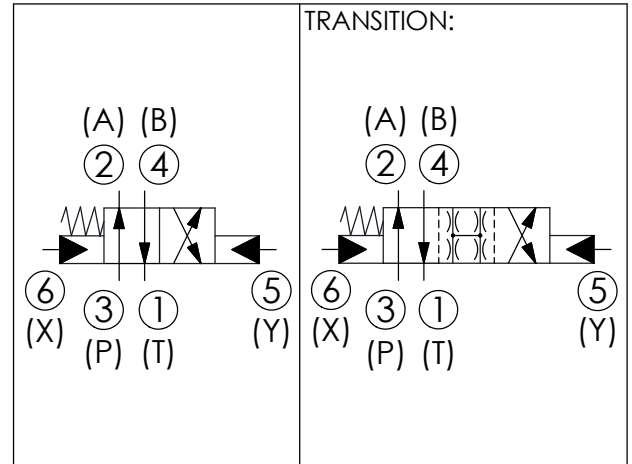
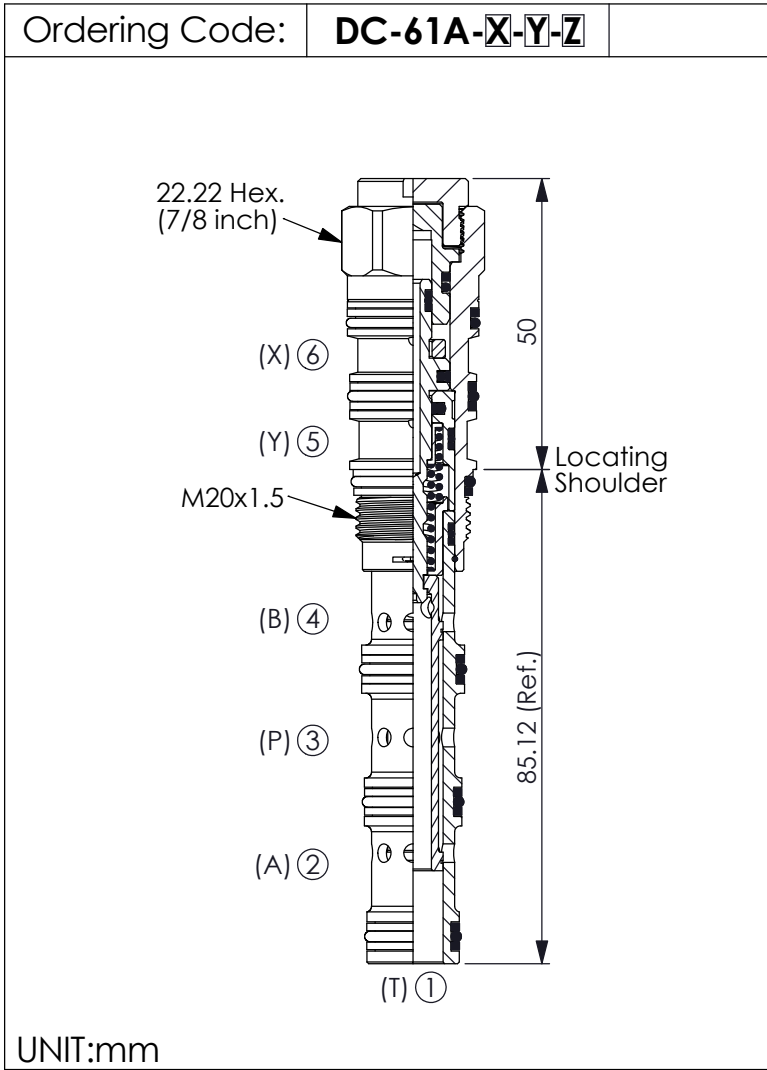

TECHNICAL DATA

Max. pressure:	350	bar
Rated flow:	28-40	l/min (Refer To Performance Chart)
Cavity-Tooling:	61A-6	
Installation torque:	40-50	Nm
Weight:	0.200	kg
<ul style="list-style-type: none"> • Minimum Pilot Pressure Required to Shift Valve : 12 bar. • Maximum Leakage Approximately (30 cc/min./70 bar) • All ports will accept 350 bar. 		

Performance Chart

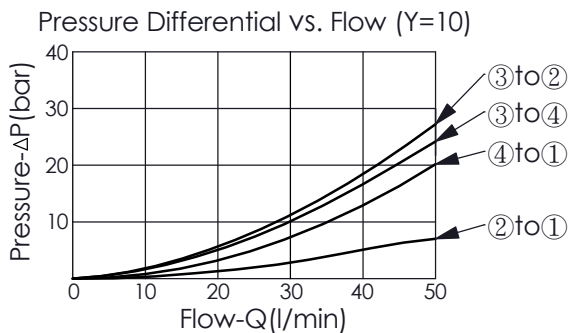

X OPERATION

6E Pilot-to-shift

Y SPOOL CONFIGURATION

10 Spool 4-Way, 2-Position

Z OPTIONS

N Non-adjustable