

DIRECTIONAL VALVE (4-Way, 2-Position Spool, Pilot-to-shift, Detented)

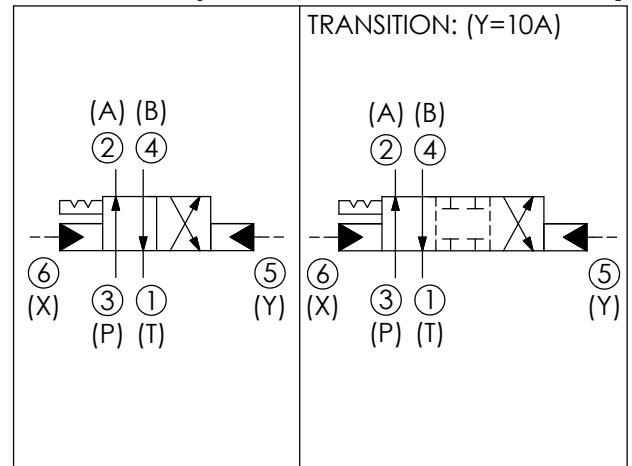
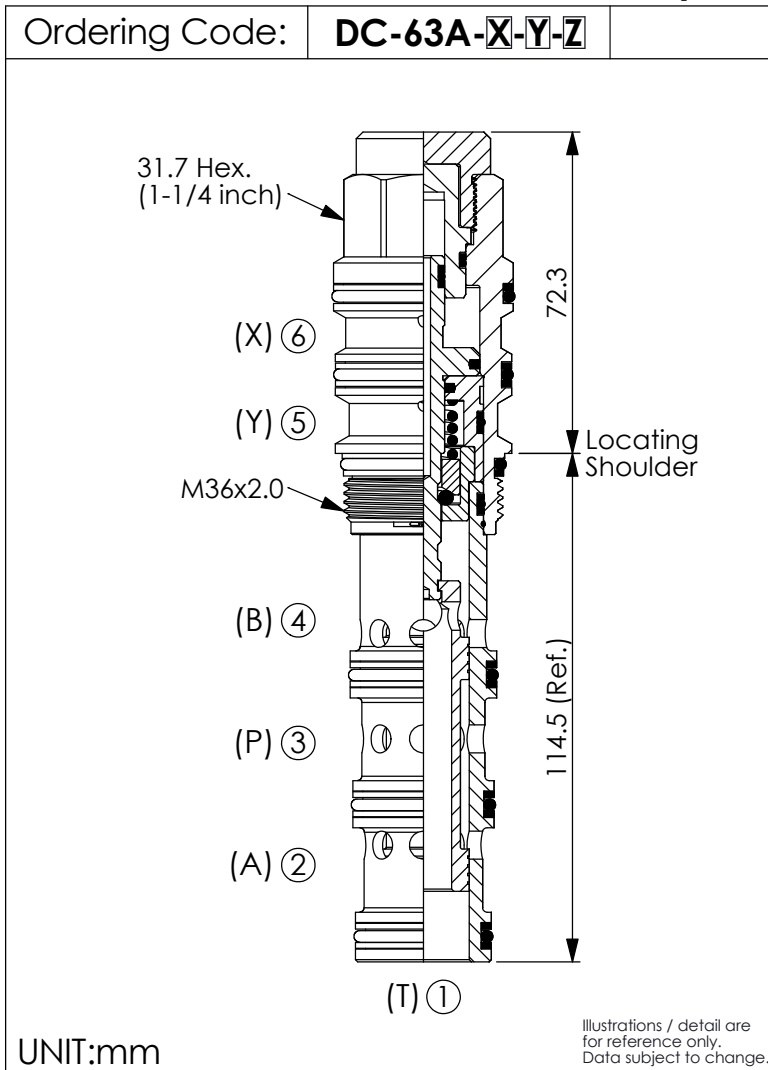

TECHNICAL DATA

Max. pressure:	350	bar
Rated flow:	160 - 240	l/min (Refer To Performance Chart)
Cavity-Tooling:	63A-6	
Installation torque:	200 - 215	Nm
Weight:	0.845	kg
<ul style="list-style-type: none"> Minimum Pilot Pressure Required to Shift Valve : 9 bar. Maximum Leakage Approximately (30 cc/min./70 bar) All ports will accept 350 bar. 		

Performance Chart

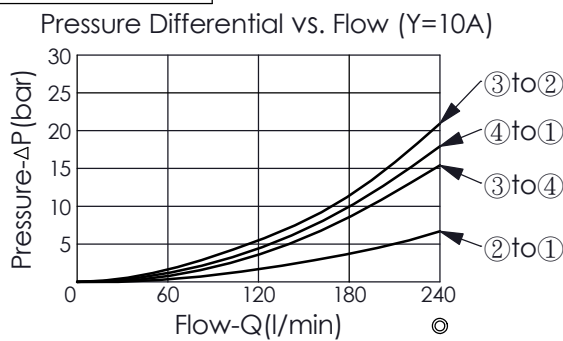

X OPERATION

6D Pilot-to-shift, Detented

Y SPOOL CONFIGURATION

10A

Spool 4-Way, 2-Position, Port ③ to Port ②, Port ④ to Port ①, 4 Ports Blocked At Transition Position, After Transition, Port ③ to Port ④, Port ② to Port ①

Z OPTIONS

N Non-adjustable