

Ordering Code: **DD-2A-X-Y-Z**

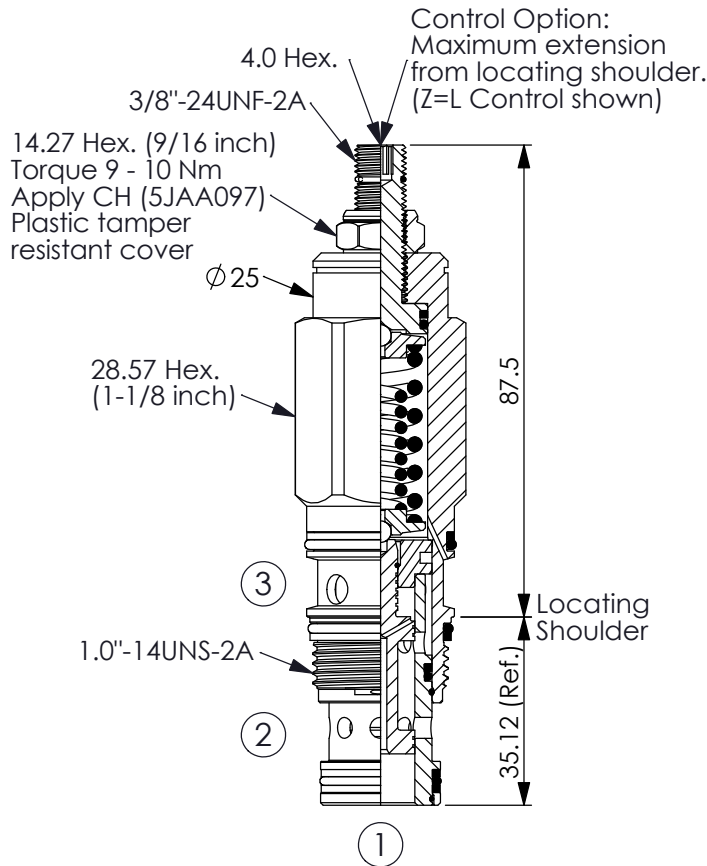

UNIT:mm

Illustrations / detail are
for reference only.
Data subject to change.

TECHNICAL DATA

Max. pressure: 350 bar

Rated flow: 60 l/min

Cavity-Tooling: 2A-3

Installation torque: 60 - 70 Nm

Weight: 0.335 (Z=L) kg

• Pressure at Port ③ is added to the valve setting directly, so we do not recommend Port ③ as a work port. If there is a requirement, please consider DD- *-4Q- \square - \square .

OPERATION

X

3Q

Port ② to Port ③,
Port ① pilot to shift,
Port ① to Port ②

• Maximum Leakage Approximately
(30 cc/min.)

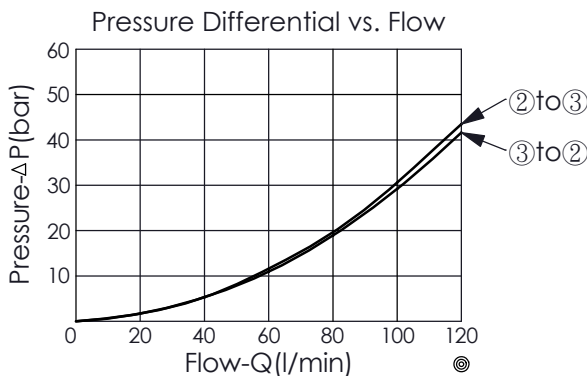

PRESSURE SETTING

A 50 - 210 bar (70 bar Standard Setting)

B 20 - 105 bar (35 bar Standard Setting)

D 14 - 55 bar (28 bar Standard Setting)

E 7 - 28 bar (14 bar Standard Setting)

S 3.5 - 14 bar (7 bar Standard Setting)

OPTIONS

L Leakproof hex.
socket screw.

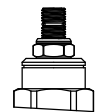

CB Plastic Tamper
Resistant Cover
(Order Code:5JAA098)

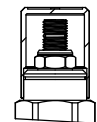

K Handknob with
Lock Knob.
(Order Code: 6ZAK001)

