

DIRECTIONAL VALVE (Piloted 2-Position 3-Way Spool) (Vented, Atmospherically Referenced)

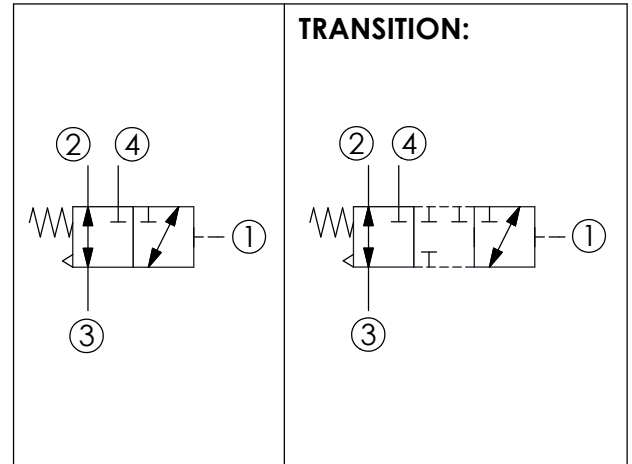

TECHNICAL DATA		
Max. pressure:	240	bar
Rated flow:	80	l/min
Cavity-Tooling:	12W-4	
Installation torque:	45 - 55	Nm
Weight:	0.28	kg

· Approximately 1 drop (0.07 cc) of fluid will pass from the pilot area to the vented spring chamber every 4000 cycles.

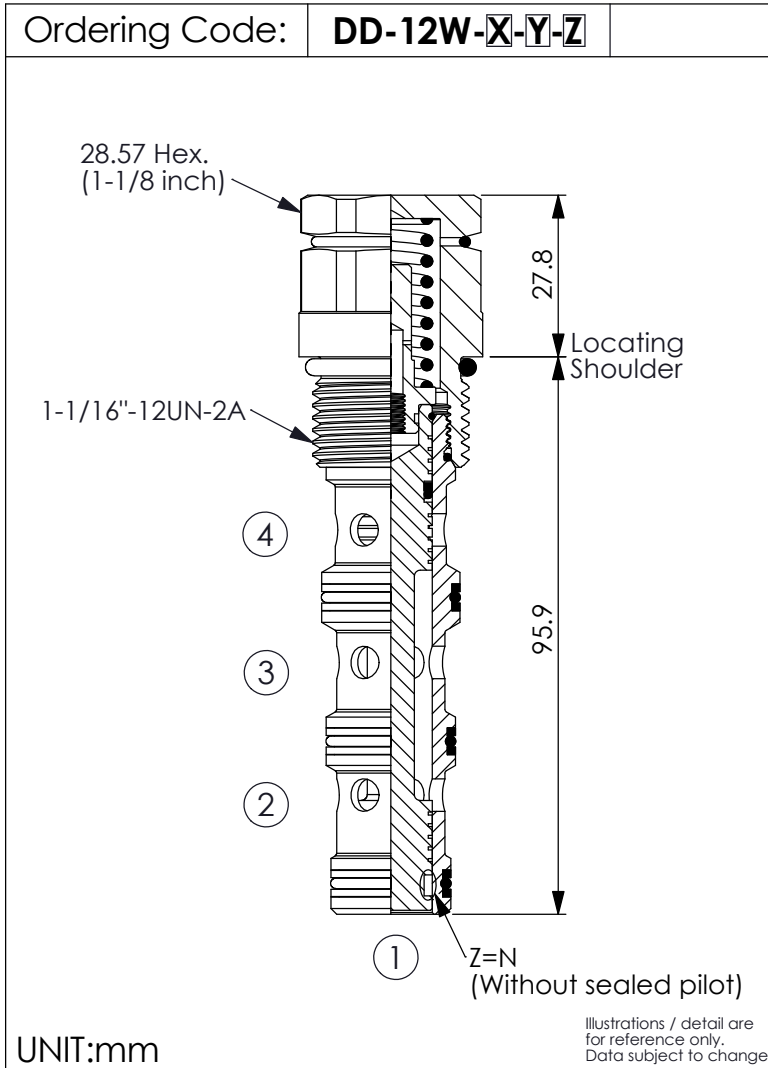
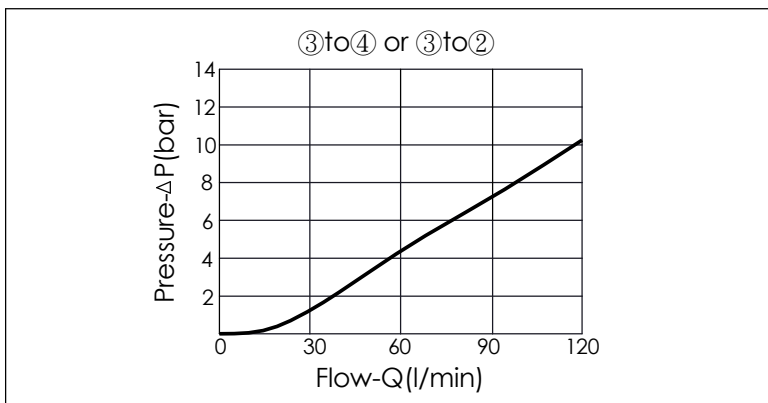

X	OPERATION	
4S	Port ② to Port ③; Port ① pilot to shift, Port ③ to Port ④	

Y	SPRINGS	
	Cracking pressure	
70	7.0 bar	
117	11.7 bar	
150	15.0 bar	

Z	OPTIONS	
N	Non-adjustable (Port ① spool without sealed pilot)	
N5	Non-adjustable (Port ① spool with sealed pilot)	