

(3-Way, 2-Position, Pilot Operated, With Internal Drain To Port ③, Normally Open)

DIRECTIONAL VALVE

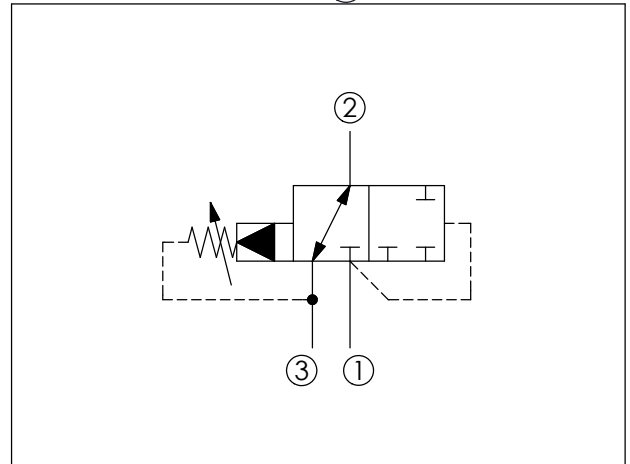
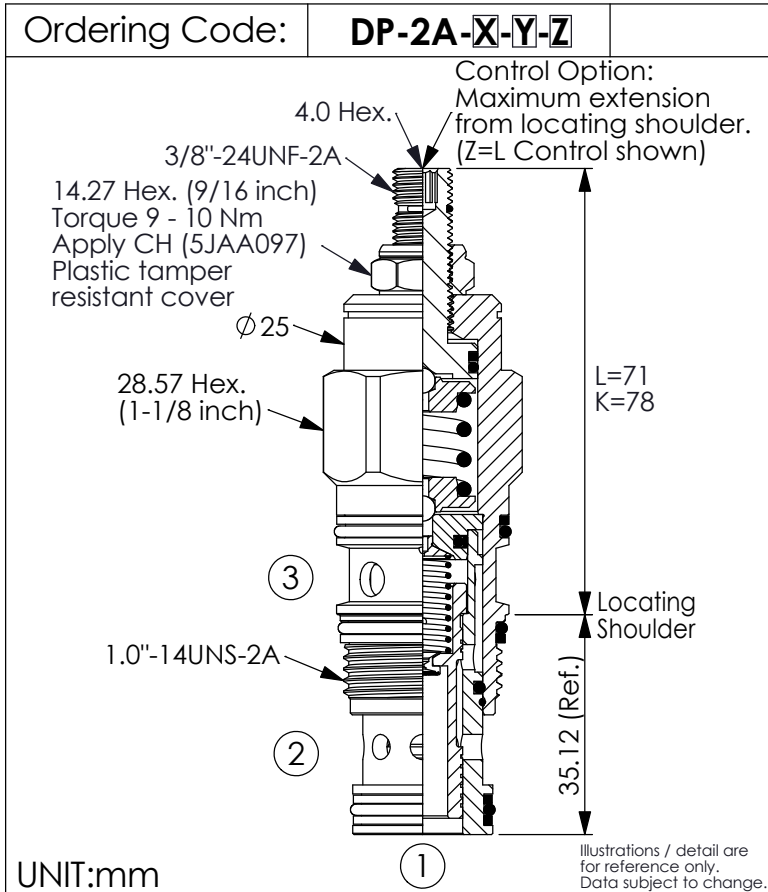

TECHNICAL DATA

Max. Operating pressure:	350 bar
Rated flow:	60 l/min
Cavity-Tooling:	2A-3
Installation torque:	60 - 70 Nm
Weight:	0.263 (Z=L) kg

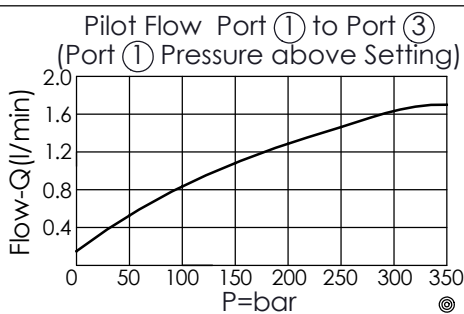
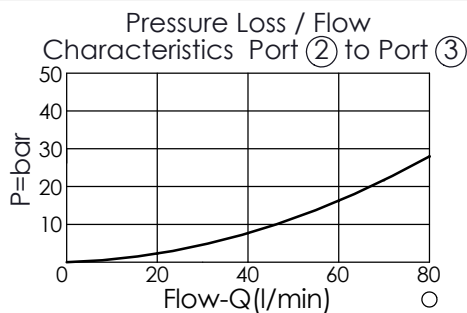

X OPERATION

3M Normally open, Port ② to Port ③; Port ① pilot to shift, three ports closed

· When the pressure at port ① exceed the setting pressure, there is a control pilot flow (0.16 - 0.25 L/min.)

Z OPTIONS

L	Leakproof hex. socket screw.	
K	Handknob with Lock Knob. (Order Code: 6ZAK001)	
C	Stainless Steel Tamper Resistant Cover.	

Y SPRINGS

ADJUSTMENT RANGES

A	7 - 210 bar (70 bar Standard Setting)
B	3.5 - 105 bar (70 bar Standard Setting)
C	10.5 - 420 bar (210 bar Standard Setting)
D	1.7 - 55 bar (28 bar Standard Setting)
E	1.7 - 28 bar (14 bar Standard Setting)
W	7 - 315 bar (70 bar Standard Setting)