

Ordering Code: **FD-31A-X-Y-Z**

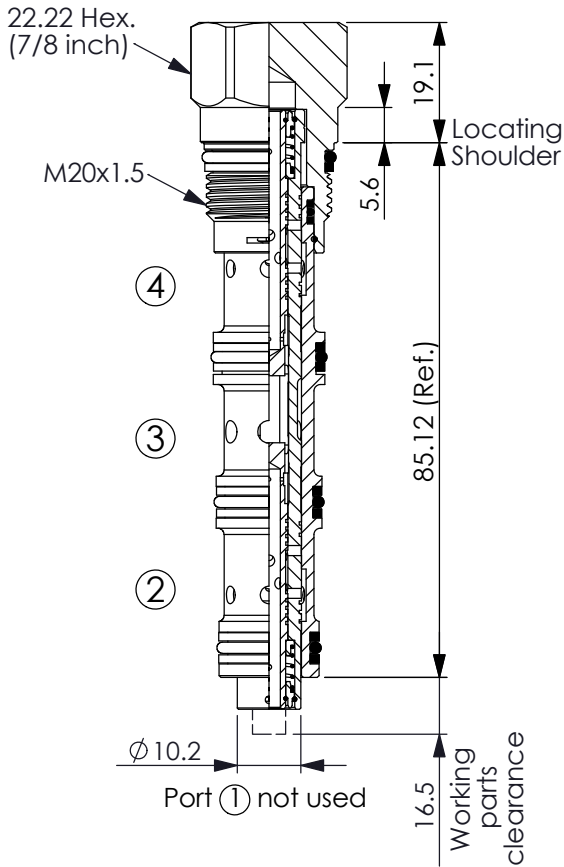

UNIT:mm

Illustrations / detail are for reference only. Data subject to change.

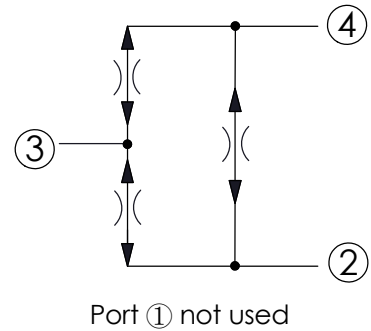

### TECHNICAL DATA

Max. Operating pressure: 350 bar

Divisional accuracy at rated maximum inlet flow =  $50\% \pm 2.5\%$

Divisional accuracy at rated minimum inlet flow =  $50\% \pm 4.5\%$

Cavity-Tooling: 31A-4

Installation torque: 40 - 50 Nm

Weight: 0.16 kg

### Capacity:6-32 LPM

Split	Inlet Flow		Rated Accuracy	Maximum Possible Flow Variation
	Max Rated	Min Rated		
50:50	32 L/min	6 L/min	$\pm 2.5\%$	14.3 - 15.8 L/min
			$\pm 4.5\%$	2.73 - 3.27 L/min
Tolerance of Synchronizing Flow				0.94 - 2.46 L/min

The maximum possible variation is at 350 bar differential between legs with high pressure leg being the higher flow in dividing mode and the lower flow in combining mode

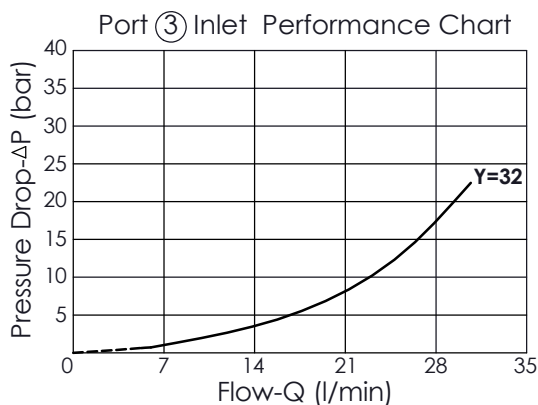

### X OPERATION

**42** 4 Ports;  
Flow Divider/Combiner  
(Anti-Stall Features)  
(This type will keep a flow to both combining ports ② and ④ when port ② or ④ is "free-wheeling." This function keeps parallel hydraulic-motor drive circuits from stalling in the combining mode.)

### Y NOMINAL CAPACITY

**32** 6 - 32 LPM

### Z OPTIONS

**N** Non-adjustable

