

## FLOW DIVIDER VALVE

Ordering Code: **FD-31A-X-Y-Z**

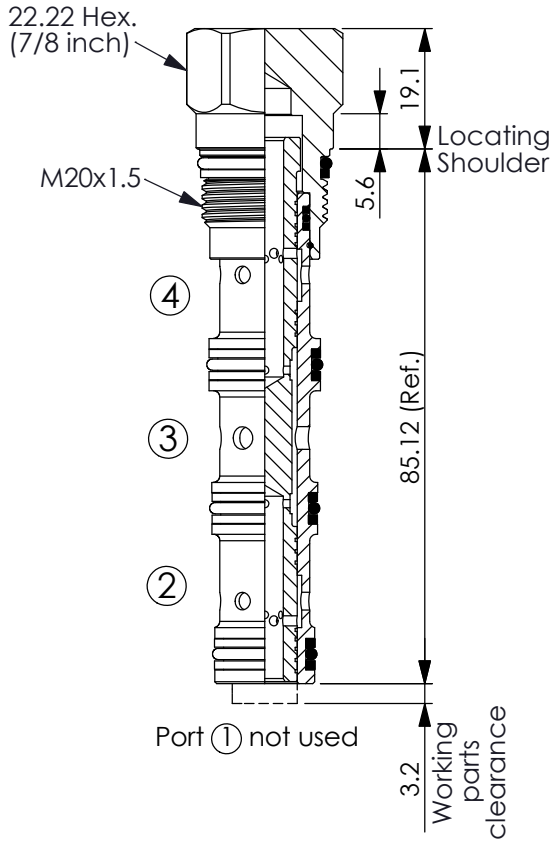

UNIT:mm

Illustrations / detail are for reference only. Data subject to change.

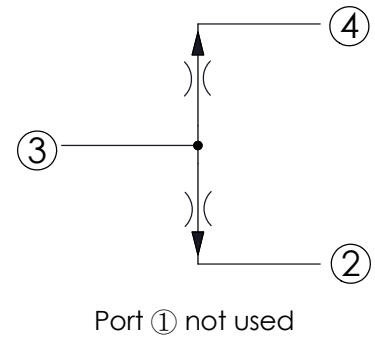

### TECHNICAL DATA

Max. Operating pressure: 350 bar

Divisional accuracy at rated maximum inlet flow = 30 l/min  $\pm$ 3.5%

Divisional accuracy at rated minimum inlet flow = 6 l/min  $\pm$ 6.5%

Cavity-Tooling: 31A-4

Installation torque: 40 - 50 Nm

Weight: 0.151 kg

### Capacity: 6 - 30 LPM

Split	Inlet Flow		Rated Accuracy	Maximum Possible Flow Variation
	Max. Rated	Min. Rated		High Flow Leg
50:50	30 L/min	6 L/min	$\pm$ 3.5%	14.1 - 15.9 L/min
	6 L/min	30 L/min	$\pm$ 6.5%	2.5 - 3.5 L/min

The maximum variation is at 350 bar differential between legs with the high pressure leg being the higher flow.

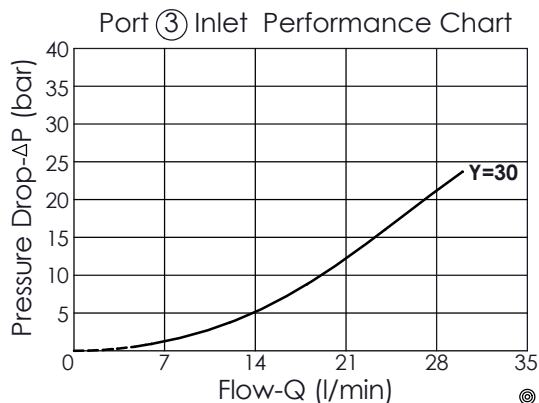

### X OPERATION

**41** 4 Ports; Flow Divider

### Y NOMINAL CAPACITY

**30** 6 - 30 LPM

### Z OPTIONS

**N** Non-adjustable

