

Ordering Code: **HB-G04-Y-Z**

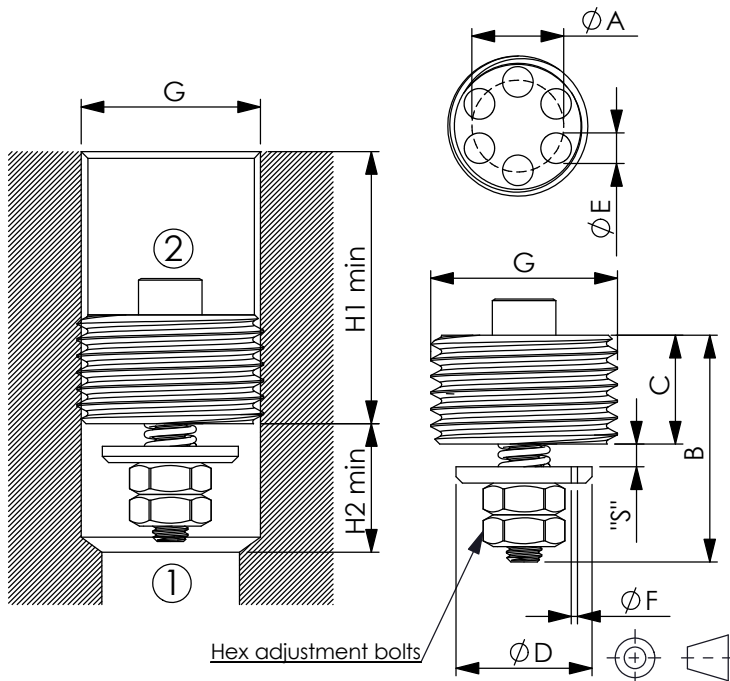

UNIT:mm

Illustrations / detail are for reference only. Data subject to change.

X=	G	A	B	C	D	E	F	H1	H2	Hex
G04	G 1/2"	13	25	12	15	4.5	on request	30	15	7

The valve is only supposed to be operated in case of hose failure. In the case of a hose failure, flow increases across the valve until the maximum safe limit is reached at which point the valve will close. The "S" gap must be adjusted to allow a flow at least 50% over the nominal regulated flow from the actuator. These valves can be supplied (on request) with an orifice on the disc, allowing an emergency lowering of load. It is recommended to fit a flow regulator valve downstream the hose burst valve, at the end of the flexible hose, to control the lowering speed at the nominal value.

Performance curves R/flow (allowance can be $\pm 10\%$ from the curve)
After assembling the valves are preadjusted at the following valves
"S"= 2.5 mm

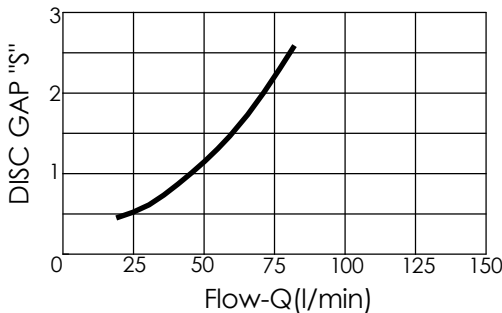

Flow performance from ② to ① depending on S-length

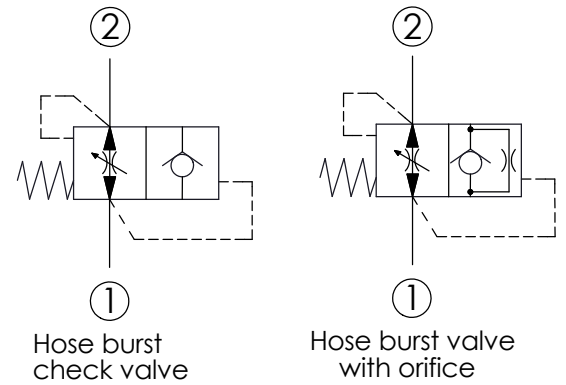
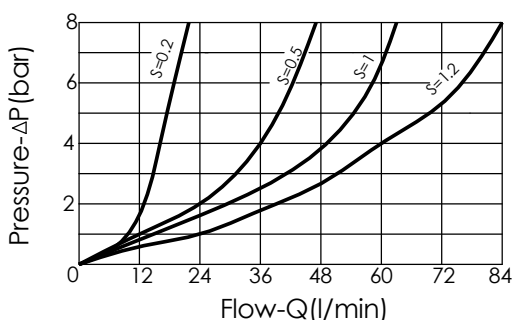

TECHNICAL DATA

Max. pressure: 350 bar

Flow: see below graphs ("S"-Q)

Special flow settings are available. Please contact factory authorized representative for ordering code.

Weight kg	Flow		TIGHTENING TORQUE Cartridge Nm
	min	max	
0.025	16	80	3 \pm 1

Y OPERATION

20 Standard Type

Z ORIFICE DIAMETER (mm)

00	no orifice	10	1.0
05	0.5	12	1.2
06	0.6	13	1.3
07	0.7	15	1.5
08	0.8	19	1.9
09	0.9	20	2.0

FITTING TOOL DIMENSION

14.0 Hex.
(9/16 inch)

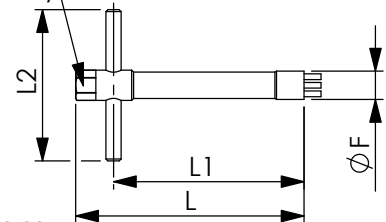

UNIT:mm

F	L	L1	L2	Tool's ordering code
18.8	120	108	80	HBG04-T