

LOGIC ELEMENT VALVE (Pilot-to-closed, Normally open, balanced poppet, logic element)

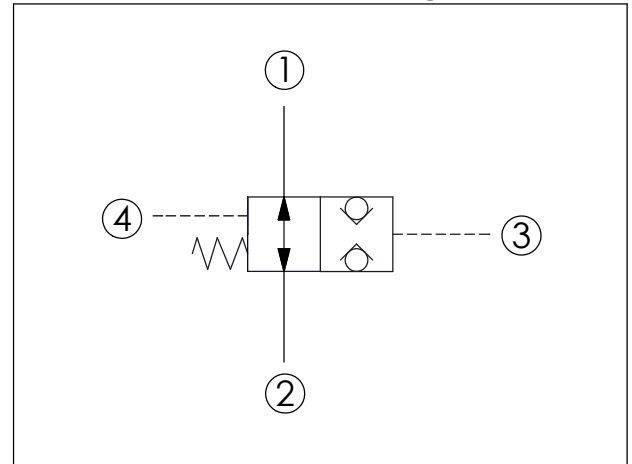

TECHNICAL DATA	
Max. Operating pressure:	350 bar
Rated flow:	480 l/min
Cavity-Tooling:	24A-4 (24AB-4)
Installation torque:	465 - 500 Nm
Weight:	1.52 kg

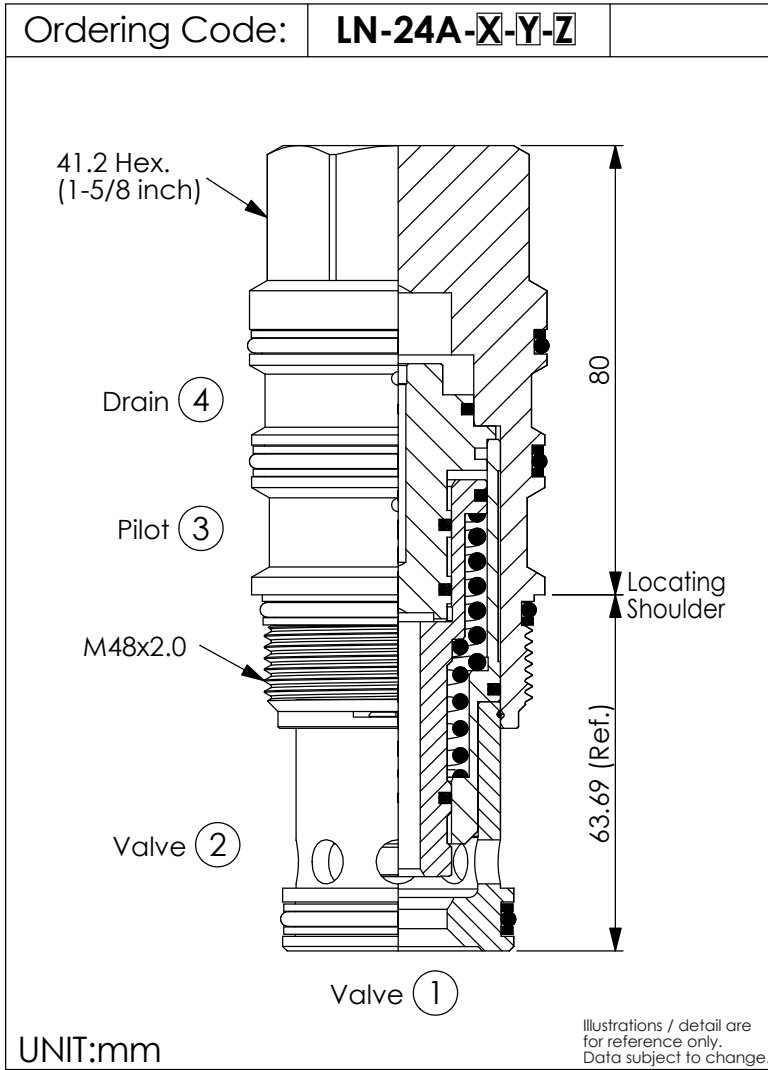
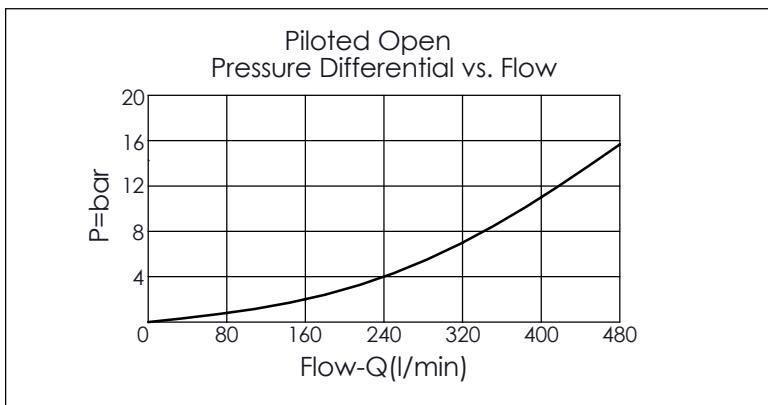

X	OPERATION	
4S	Pilot-to-closed	
<ul style="list-style-type: none"> Maximum Leakage Approximately (0.7 cc/min.) All ports will accept 350 bar. 		

Y	SPRINGS	
	Recommendation of Minimum Pilot Pressure Required to Shift Valve (Port ③)	
20	20.0 bar	
<ul style="list-style-type: none"> We suggest that using above 20 bar pilot pressure at Port ③ when Port ① and Port ② are 350 bar. In order to ensure shifting quickly for every kinds of pressure and flow. 		

Z	OPTIONS	
N	Non-adjustable	