

## LOGIC ELEMENT VALVE (Spool Type Normally Open Modulating Element)

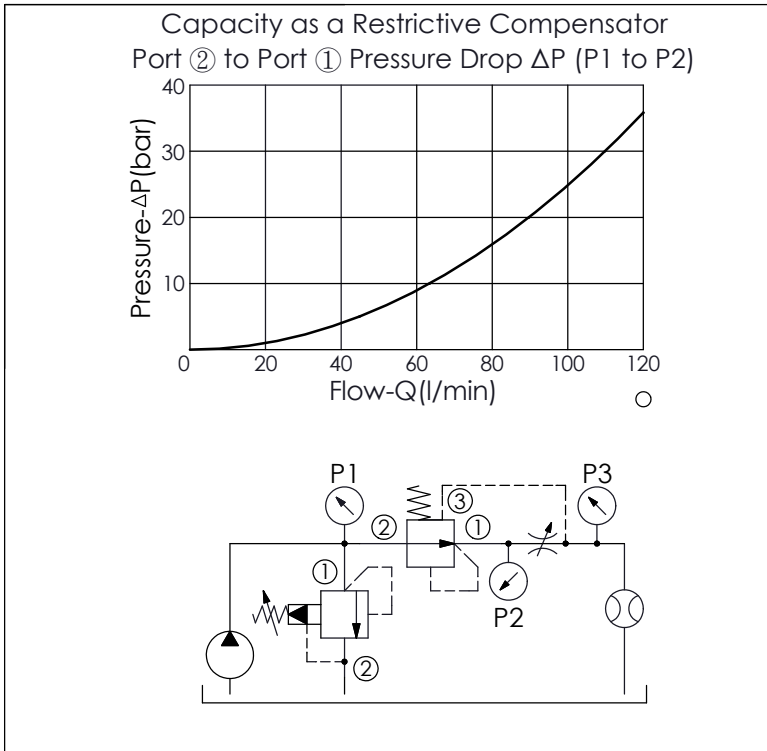
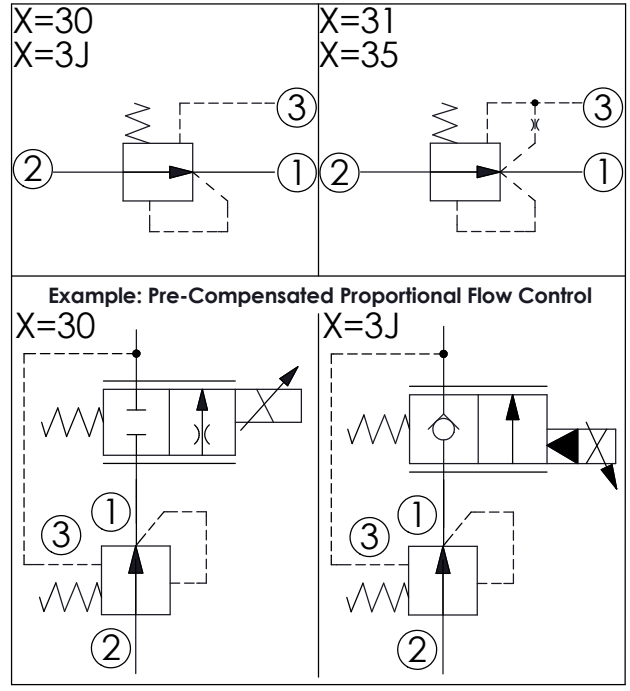
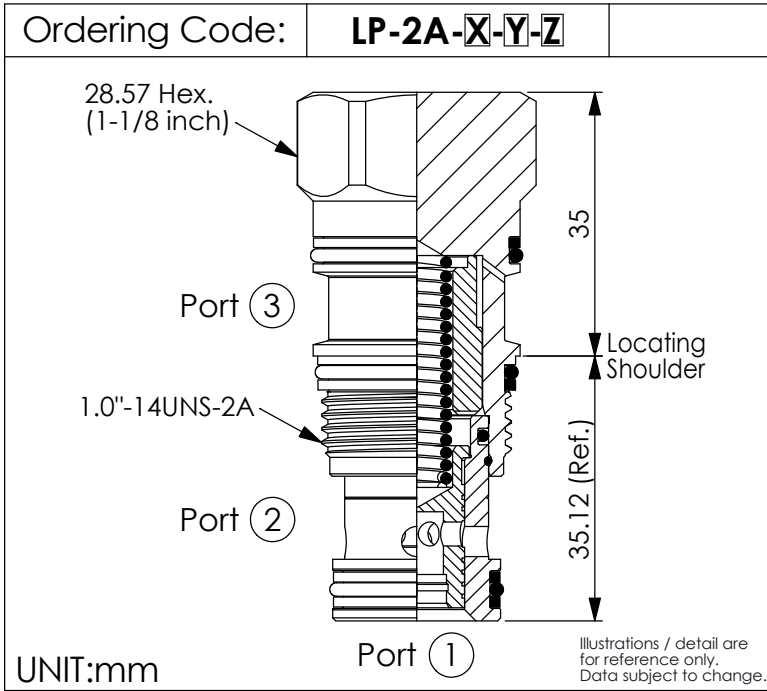

TECHNICAL DATA	
Max. Operating pressure:	350 bar
Rated flow:	120 l/min (Refer to performance chart)
Cavity-Tooling:	2A-3
Installation torque:	60 - 70 Nm
Weight:	0.227 kg

Y	SPRINGS	
	Cracking pressure	
35	3.5 bar	
70	7.0 bar	
100	10.0 bar	
140	14.0 bar	
200	20.0 bar	

Z	OPTION	
	N	Non-adjustable

X	OPERATION	
30	External Pilot (restrictive compensator) (If bigger flow or bigger pressure difference is needed, please choose <b>PD-*-3J</b> ) (If you need bigger orifice, please consult our sales department)	
31	Internal Pilot Port ① to Port ③ (mainstage reducing element)	
35	Internal Pilot Port ① to Port ③ (mainstage reducing element) (Impact Resistant Type) (No Copper Seat Filter)	
3J	External Pilot (restrictive compensator) (with sealed piston) *For example: to use together with PEP series proportional valves	