

LOGIC ELEMENT VALVE (Spool Type Normally Closed Modulating Element)

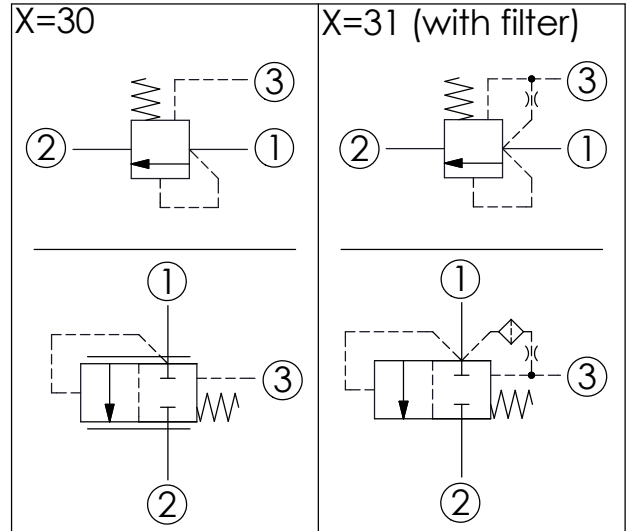

TECHNICAL DATA

Max. Operating pressure:	350 bar	
Rated flow:	60	l/min
Cavity-Tooling:	11A-3	
Installation torque:	40 - 50	Nm
Weight:	0.121 (Z=N)	kg

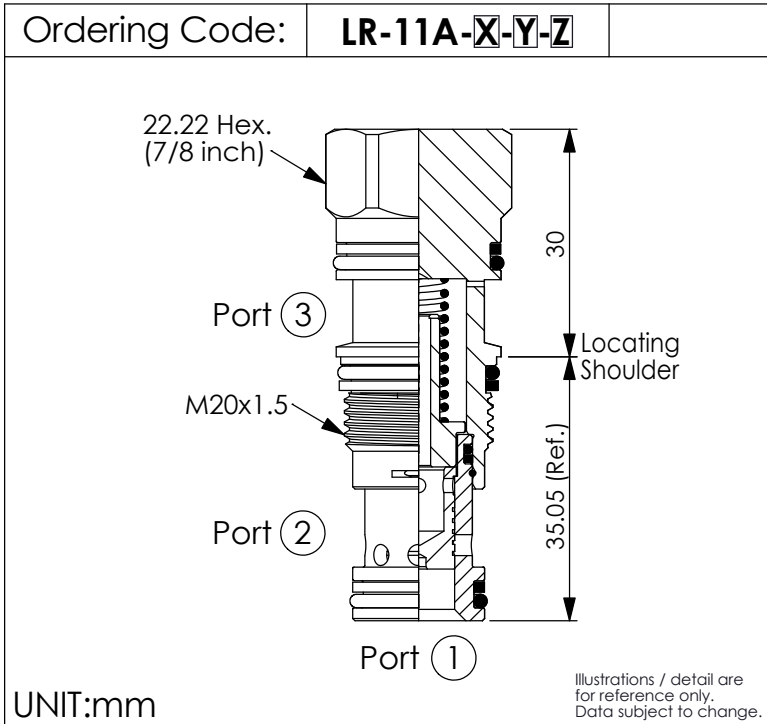
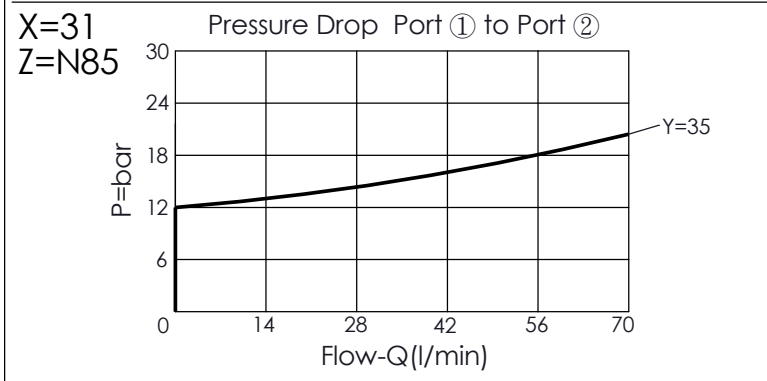
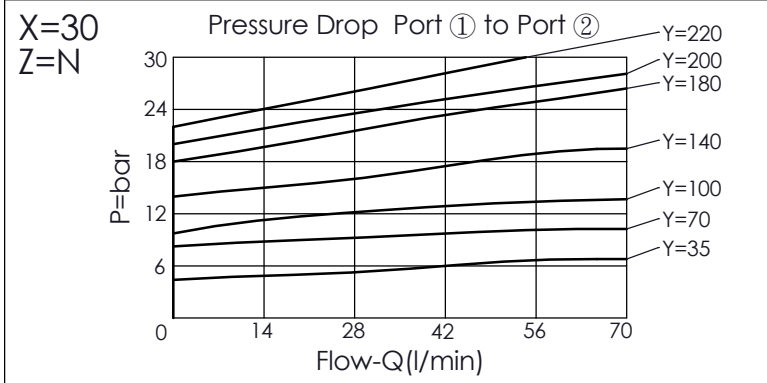

Y	SPRINGS	
	Cracking pressure	
10	1.0 bar (Only X=31)	
35	3.5 bar	
70	7.0 bar	
100	10.0 bar	
140	14.0 bar	
180	18.0 bar	
200	20.0 bar	
220	22.0 bar	

X	OPERATION	
30	External Pilot (bypass compensator)	
31	Internal Pilot (Port ① to Port ③) (mainstage relief element)	

Z	OPTION	
N	Non-adjustable	
N85	Fast-acting (Only X=31)	