

Ordering Code: **NV-20M-X-Y-Z**

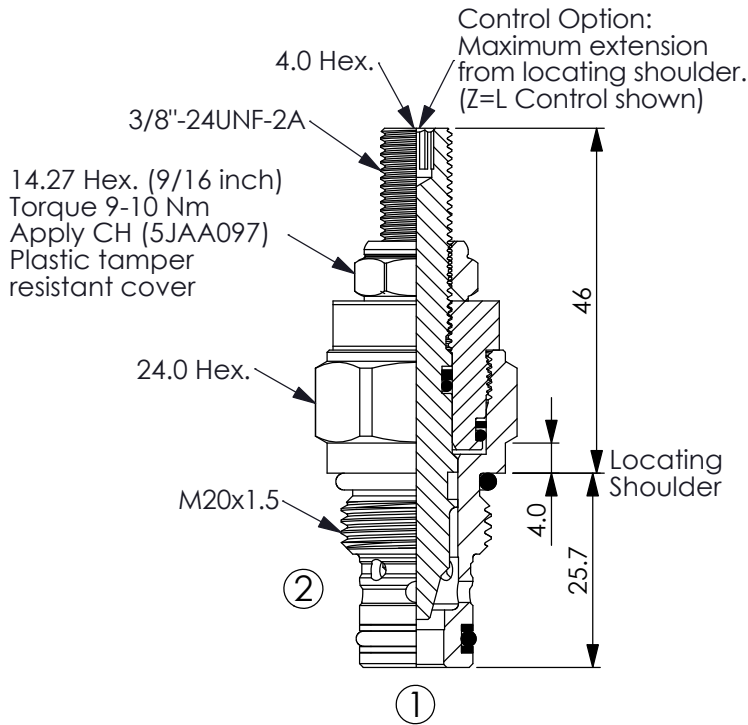

UNIT:mm

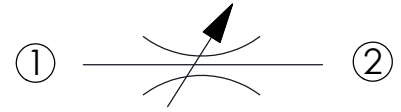

### TECHNICAL DATA

Max. operating pressure: 350 bar  
(Refer To Performance Chart)

Rated Flow: 40 l/min  
(Refer To Performance Chart)

Cavity-Tooling: 20M-2

Installation torque: 40-50 Nm

Weight: 0.13 kg

### Performance Chart

FULLY OPEN RESTRICTOR-FLOW IN BOTH DIRECTIONS

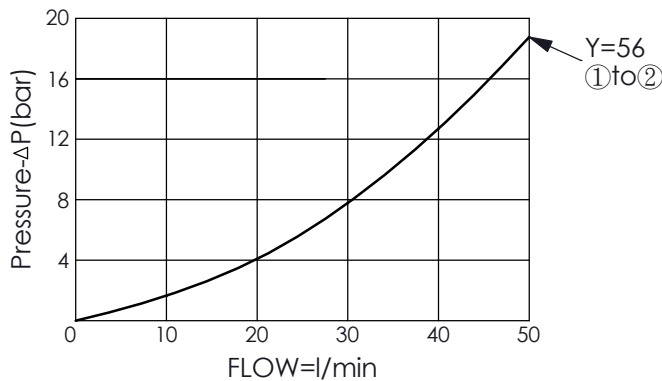

### Y MAXIMUM NOMINAL ORIFICE

**56**       $\phi$  5.6 mm

### X OPERATION

**20**      Needle Valve

### Z OPTIONS

**L**      Leakproof hex.  
socket screw.

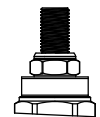

**K**      Handknob with  
Lock Knob.  
(Order Code: 6ZAK001)

