

FLOW CONTROL VALVE (Fully Adjustable Needle with Sharp-Edge Orifice)

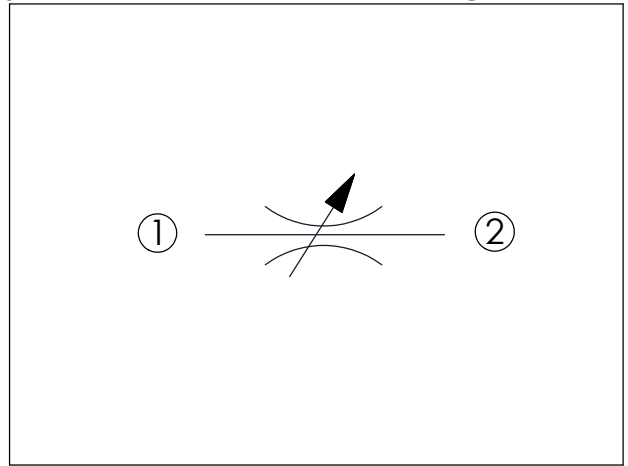

TECHNICAL DATA	
Max. pressure:	350 bar (Refer To Performance Chart)
Rated Flow:	240 l/min (Refer To Performance Chart)
Cavity-Tooling:	18A-2 (18AB-2)
Installation torque:	465 - 500 Nm
Weight:	1.14 (Z=L) kg

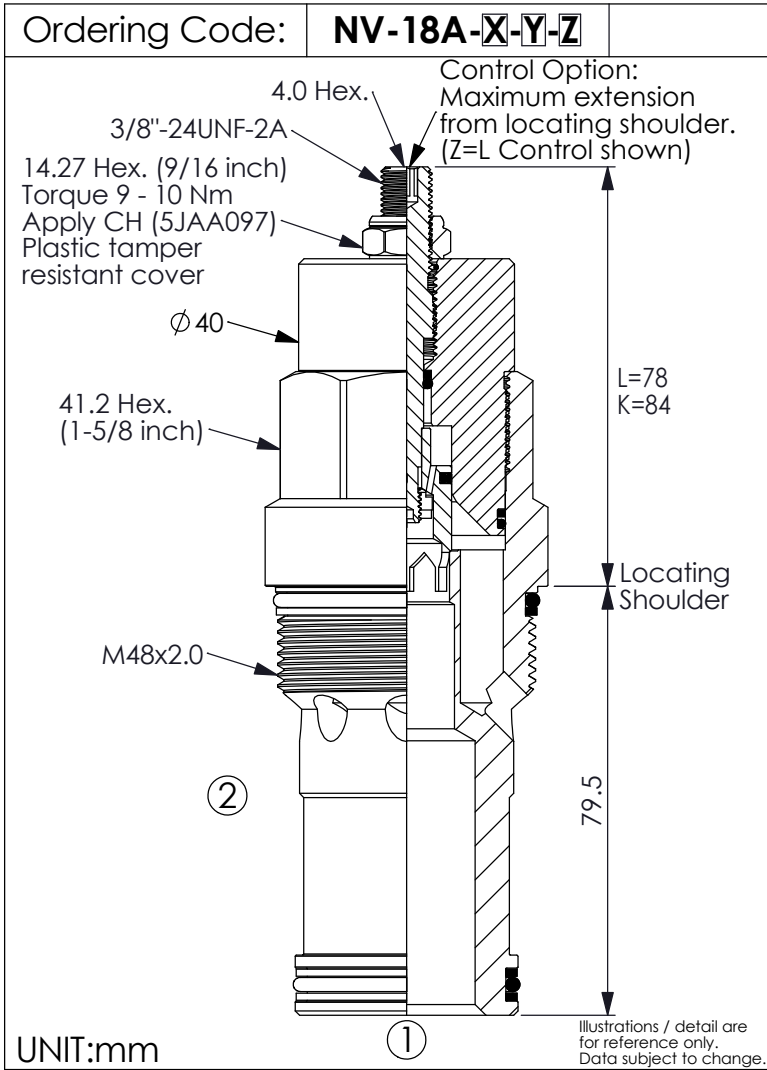
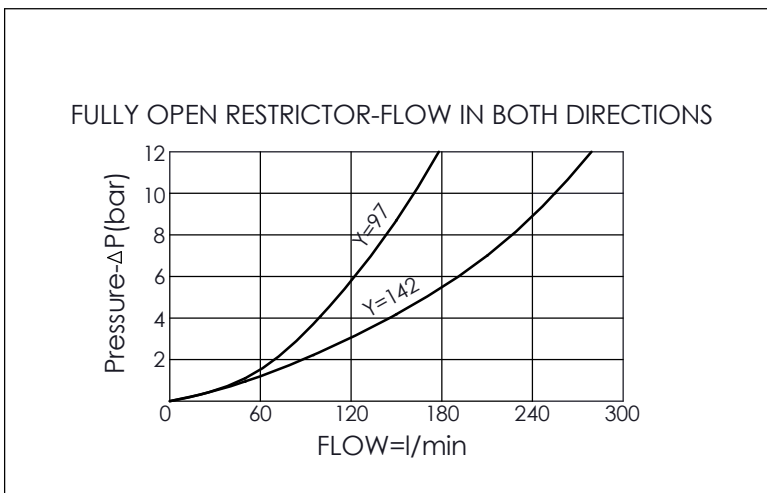

Y	MAXIMUM NOMINAL ORIFICE DIAMETER	
142	Ø 14.2 mm	
97	Ø 9.7 mm	

X	OPERATION	
20	Fully Adjustable Needle with Sharp-Edge Orifice	

Z	OPTIONS	
L	Leakproof hex. socket screw.	
K	Handknob with Lock Knob. (Order Code: 6ZAK001)	
T	Three-winged Handknob Kit.	