

Ordering Code: **NV-162A-X-Y-Z**

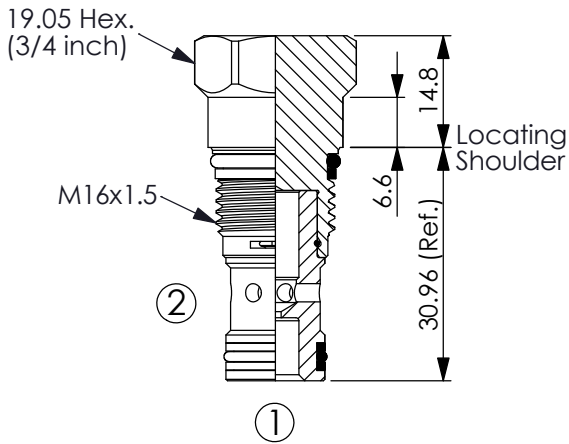

UNIT:mm

Illustrations / detail are for reference only. Data subject to change.



### TECHNICAL DATA

Max. operating pressure: 350 bar

Rated flow: 15 l/min  
(Refer To Performance Chart)

Cavity-Tooling: 162A-2

Installation torque: 27 - 33 Nm

Weight Approximately: 0.07 kg

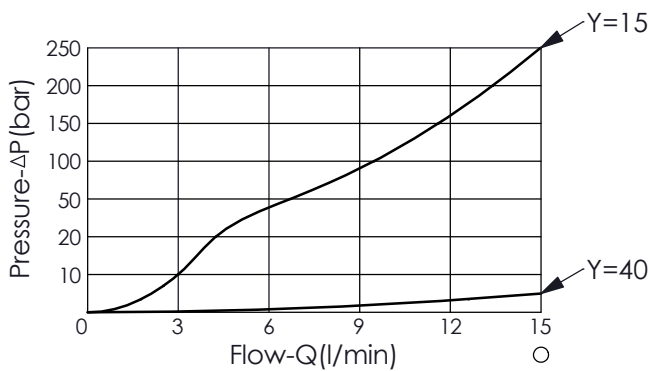

### X OPERATION

**2F** Fixed Orifice

### Z OPTIONS

**N** Non-adjustable



### Y MAXIMUM NOMINAL ORIFICE DIAMETER

**40**  $\phi$  4.0 mm

**15**  $\phi$  1.5 mm

- Customer must specify the orifice diameter.
- Refer to T.101.106.E Technical Information : ORIFICE VS. PRESSURE DROP CURVES CHART