

(Pilot Operated Reducing main stage with integral 8A control cavity)

Ordering Code: **PB-2A-X-Y-8**

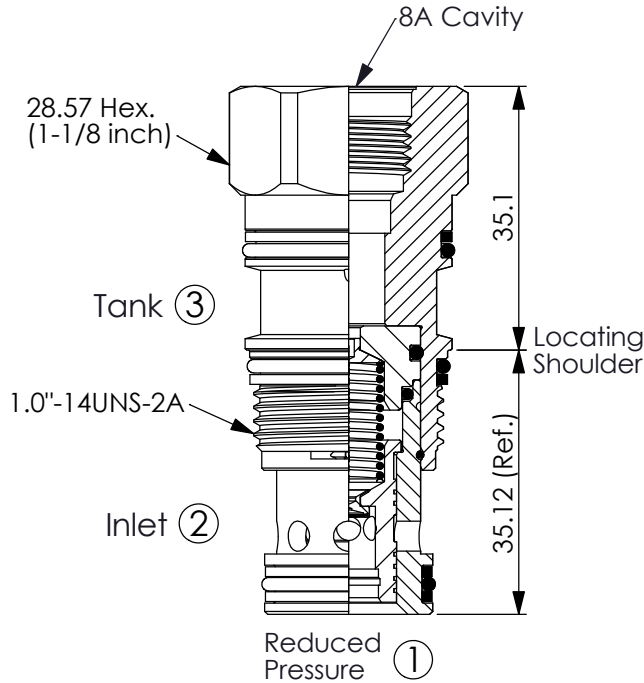

UNIT:mm

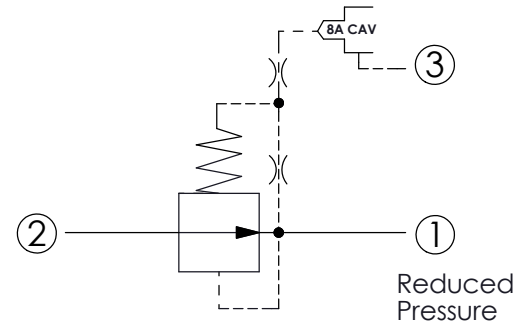

### TECHNICAL DATA

Max.Operating pressure:	350	bar
Rated flow:	80	l/min
Cavity-Tooling:	2A-3	
Installation torque:	60-70	Nm
Weight:	0.21	kg
Control Pilot Flow (0.16-0.25 L/min.)		

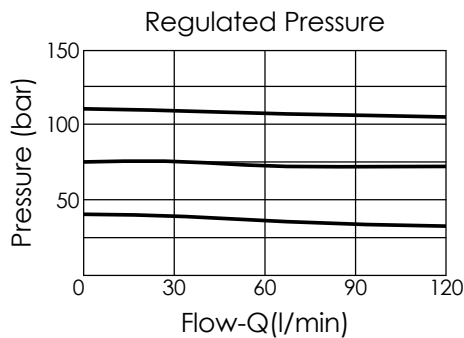

### X OPERATION

**30** Standard Type

**Y**

### SPRINGS

MINIMUM CONTROL PRESSURE

**D**

1.7 bar (25 psi)

**W**

7 bar (100 psi)

Maximum inlet pressure is determined by the bias spring. The D spring is limited to 140 bar (2000 psi) maximum differential pressure and the W spring is limited to 350 bar (5000 psi) maximum inlet pressure.