

Ordering Code: **PD-11A-X-Y-Z**

4.0 Hex.
Turn screw clockwise to increase pressure setting.

Control Option:
Maximum extension from locating shoulder.
(Z=L Control shown)

3/8"-24UNF-2A

14.27 Hex. (9/16 inch)
Torque 9 - 10 Nm
Apply CH (5JAA097)
Plastic tamper resistant cover

19

22.22 Hex. (7/8 inch)

76

Tank (3)

M20x1.5

Inlet (2)

Reduced Pressure (1)

Locating Shoulder

35.05 (Ref.)

UNIT:mm

Illustrations / detail are for reference only.
Data subject to change.

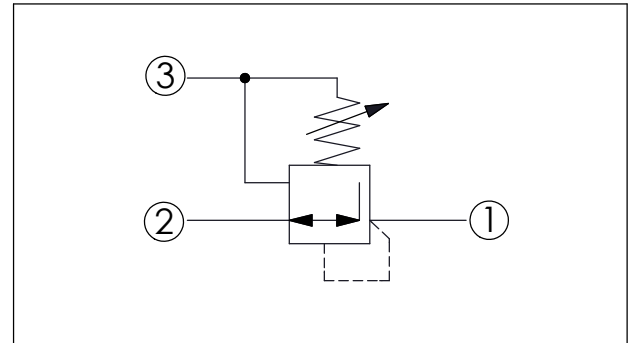

TECHNICAL DATA	
Max.Operating pressure:	350 bar
Rated flow:	40 l/min
Cavity-Tooling:	11A-3
Installation torque:	40 - 50 Nm
Weight:	0.19 (Z=L) kg

X	OPERATION
30	Standard Type
• Maximum Leakage Approximately (30 cc/min./70 bar)	

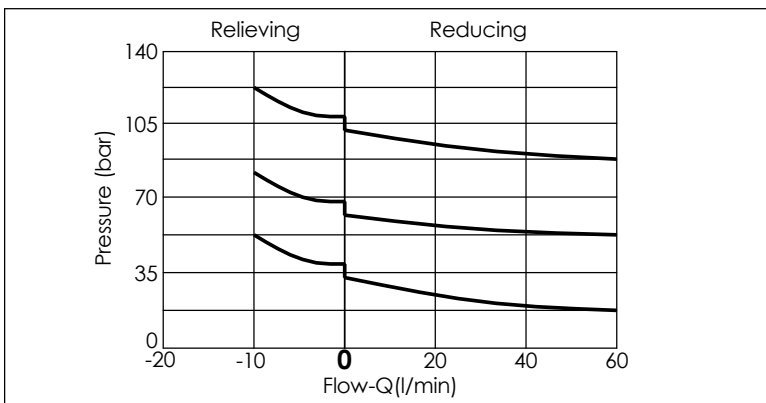

Y	SPRINGS	
	ADJUSTMENT RANGES	
A	35 - 210 bar	(50 bar Standard Setting)
B	3.5 - 105 bar	(14 bar Standard Setting)
D	1.7 - 55 bar	(14 bar Standard Setting)
E	1.7 - 28 bar	(14 bar Standard Setting)
H	7 - 210 bar	(50 bar Standard Setting)
S	1.7 - 14 bar	(7 bar Standard Setting)
W	50 - 315 bar	(70 bar Standard Setting)

Z	OPTIONS	
L	Leakproof hex. socket screw.	
LP	Leakproof hex. socket screw. With stainless steel external metal components	
C	Stainless Steel Tamper Resistant Cover.	
T	Three-winged Handknob Kit.	
KF	Handknob with Panel Mount.	
BA	Handknob and aluminum locknut.	