

PROPORTIONAL SOLENOID DIRECTIONAL VALVES (4-Way, 3-Position, Spring Centred)

Ordering Code: **PES-10W-4C-X-Y-Z**

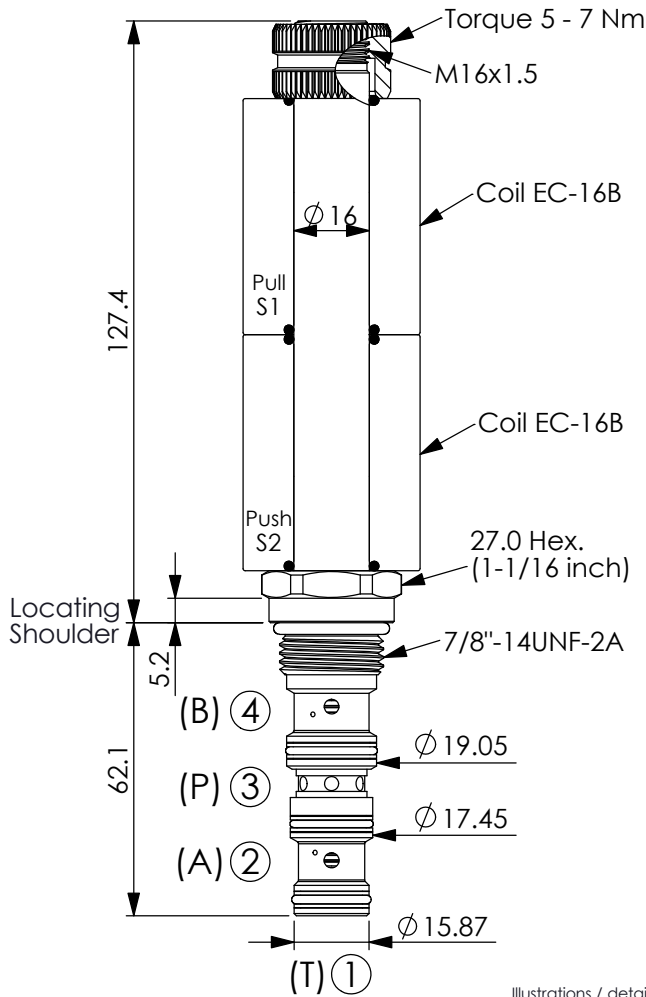

UNIT:mm

Illustrations / detail are for reference only. Data subject to change.

TRANSITION:

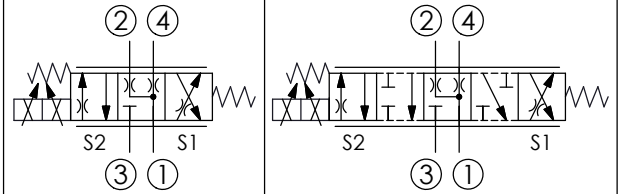

TECHNICAL DATA

Max. Operating pressure: 250 bar

Rated flow ($\Delta P=10$ bar): 22 l/min
(Refer To Performance Chart)

Cavity-Tooling: 10W-4

Installation torque: 25 - 35 Nm

Weight: 0.290 kg

Hysteresis: <4%

Threshold current:
0.5 A (12V DC coil)
0.25 A (24V DC Coil)

Maximum control current:
1.5 A (12V DC coil)
0.8 A (24V DC Coil)

Coils must be ordered separately

4 Ports - 26 Watt. Coil
 $\phi 16$ mm tube

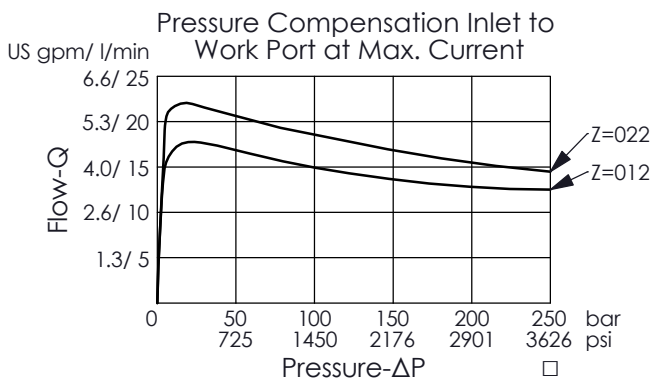
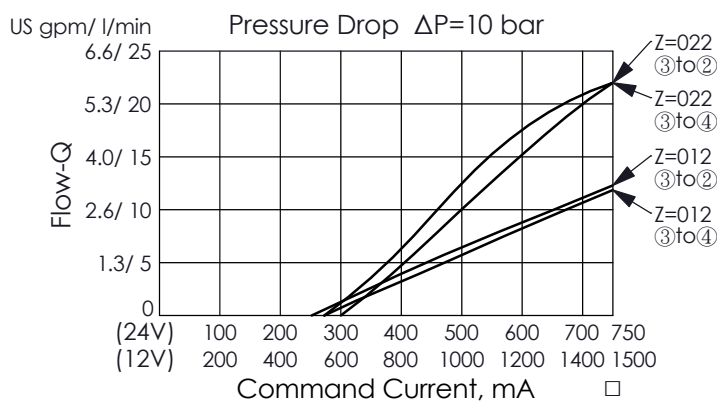

X	OPERATION
24	Spool 4-Ways, 3-Positions, A and B to T Centre

Y	OPTIONS
N	Non-adjustable

Z	FLOW
022	22 LPM
012	12 LPM