

FLOW CONTROL VALVE (Electro-Proportional, Normally Closed, Fast-acting)

Ordering Code: **PEV-16A-2D-X-Y-Z**

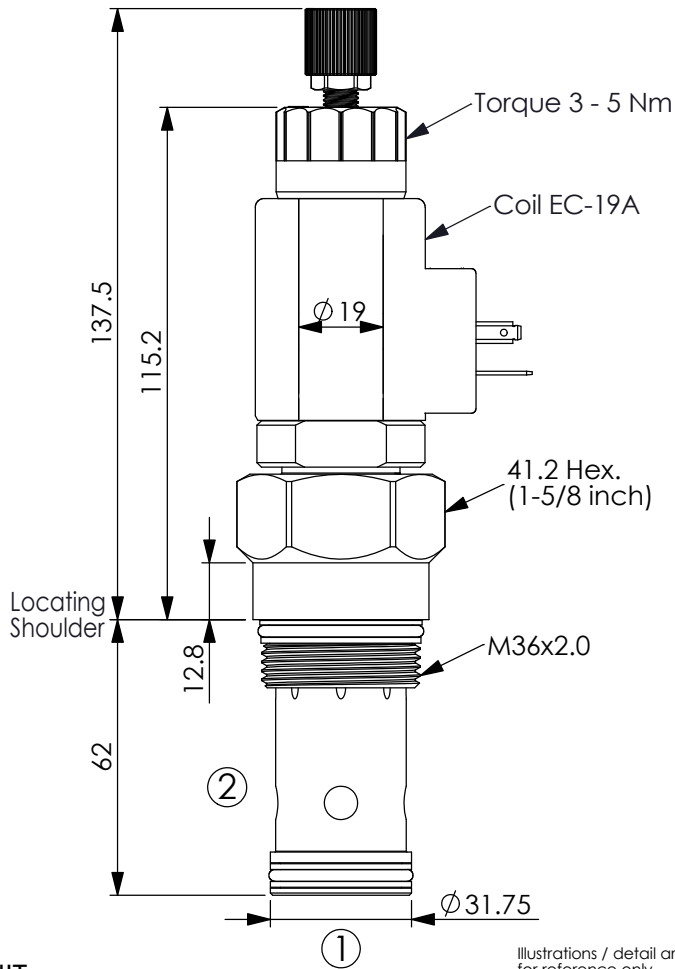

UNIT:mm

Illustrations / detail are for reference only. Data subject to change.

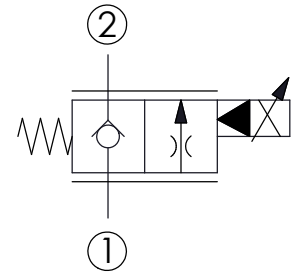

TECHNICAL DATA

Max. Operating pressure:	350	bar
Rated flow:	240	l/min
Cavity-Tooling:	16A-2	
Installation torque:	200 - 215	Nm
Weight: (with Coil)	1.05	kg
(without Coil)	0.81	kg

Leakage at ΔP of 140 bar Approximately 40 cc/minute maximum

Typical hysteresis less than 4% of rated current at 10 bar pressure drop - Pulse Width Modulated (PWM)

Recommended PWM frequency 60 - 150 HZ, application dependent, 140 HZ typical

Coils must be ordered separately

2 Ports · 22 Watt. Coil ϕ 19 mm tube

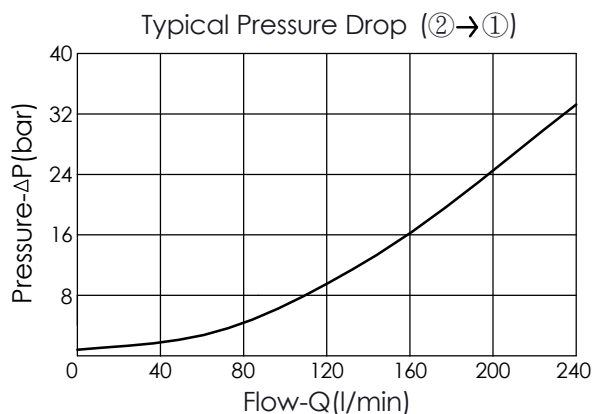
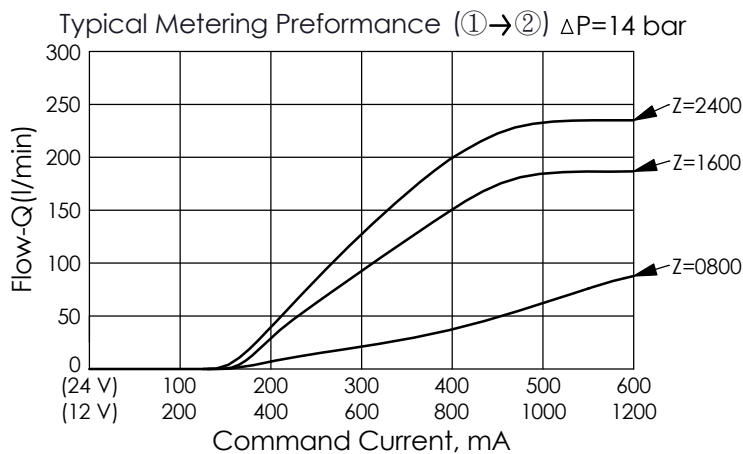

X OPERATION

09 Normally-Closed, No Reverse Flow Energized, Nose-in, Side-out Operation

Y OPTIONS

N	Non-adjustable	
M	Manual Override (Emergency Manual Proportional Flow Adjustment)	
P	Push Style Manual Override	

Z FLOW NOMINAL CAPACITY

0800	0 - 80 LPM
1600	0 - 160 LPM
2400	0 - 240 LPM

* If there is a requirement for factory minimum flow setting (port ③), please contact Winner sales department.