

FLOW CONTROL VALVE

(Electro-Proportional Flow Control Valve, Normally Open Throttle)

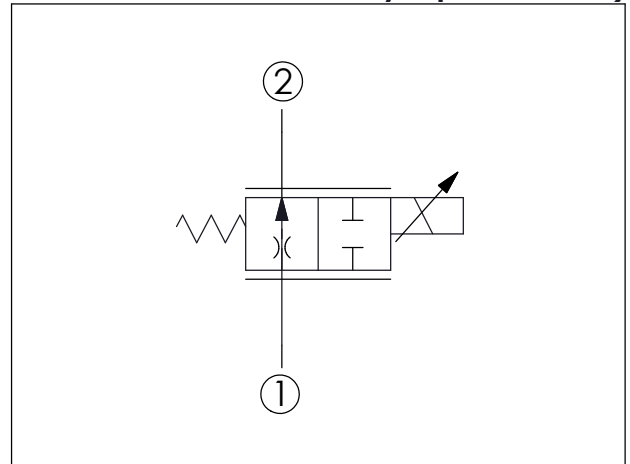
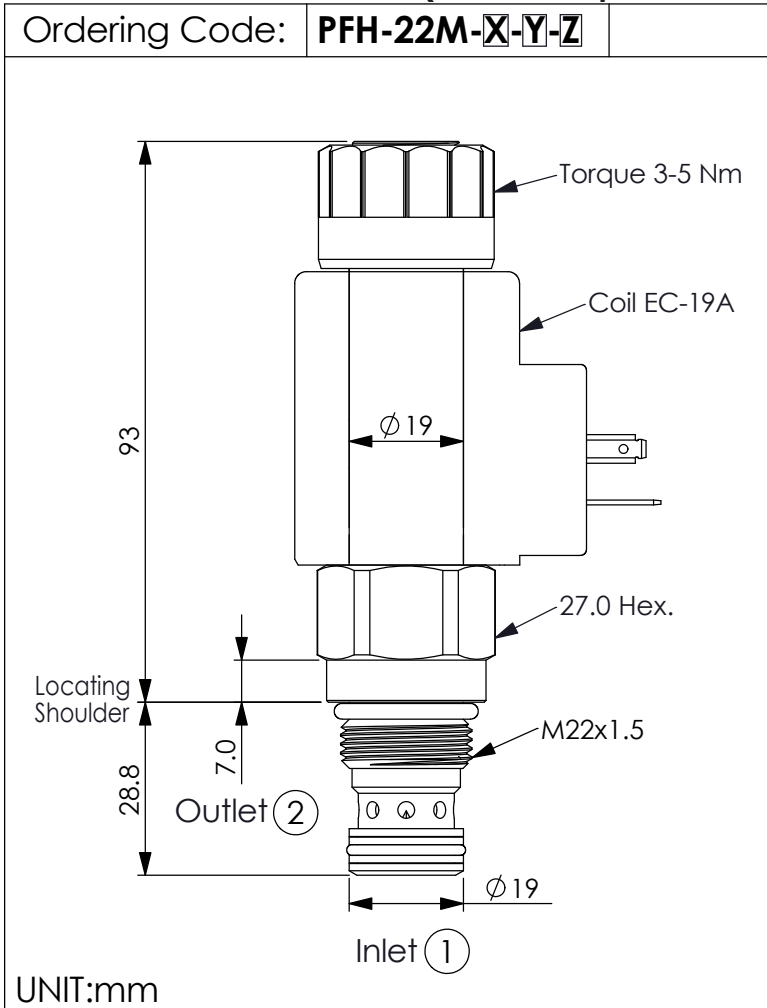

TECHNICAL DATA

Max. Operating pressure:	350	bar
Rated flow:	28	l/min
Cavity-Tooling:	22M-2	
Installation torque:	60-70	Nm
Linearity (with dither)	<2%	
Repeatability (with dither)	<2%	
Hysteresis (with dither)	<4%	
Hysteresis with DC input	<8%	
Deadband, nominal (as a percentage of input)	25%	
Weight:(with Coil)	0.73	kg
(without Coil)	0.50	kg

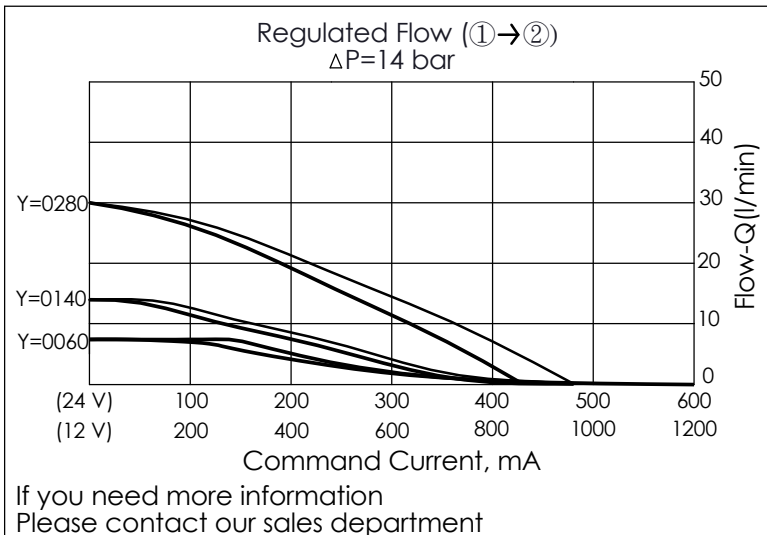

X	OPERATION	
2D	2 Ports · 22 Watt. Coil	
	Ø 19 mm tube	

Z	OPTIONS	
N	Non-adjustable	
P	Push Style Manual Override	

Y	FLOW	
	NOMINAL CAPACITY	
0060	0.4~6 LPM	
0140	0.6~14 LPM	
0280	0.8~28 LPM (Standard)	