

REDUCING/RELIEVING VALVE (Pilot Operated Reducing/Relieving)

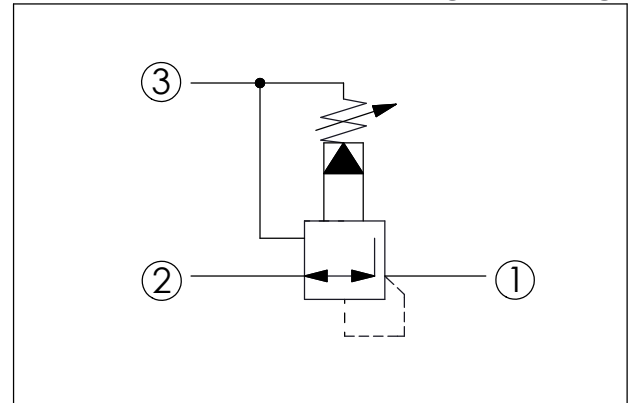

TECHNICAL DATA	
Max.Operating pressure:	350 bar
Rated flow:	160 l/min
Cavity-Tooling:	17A-3
Installation torque:	200-215 Nm
Weight:	0.56 (Z=L) kg
· Control Pilot Flow (0.25-0.33 L/min.)	

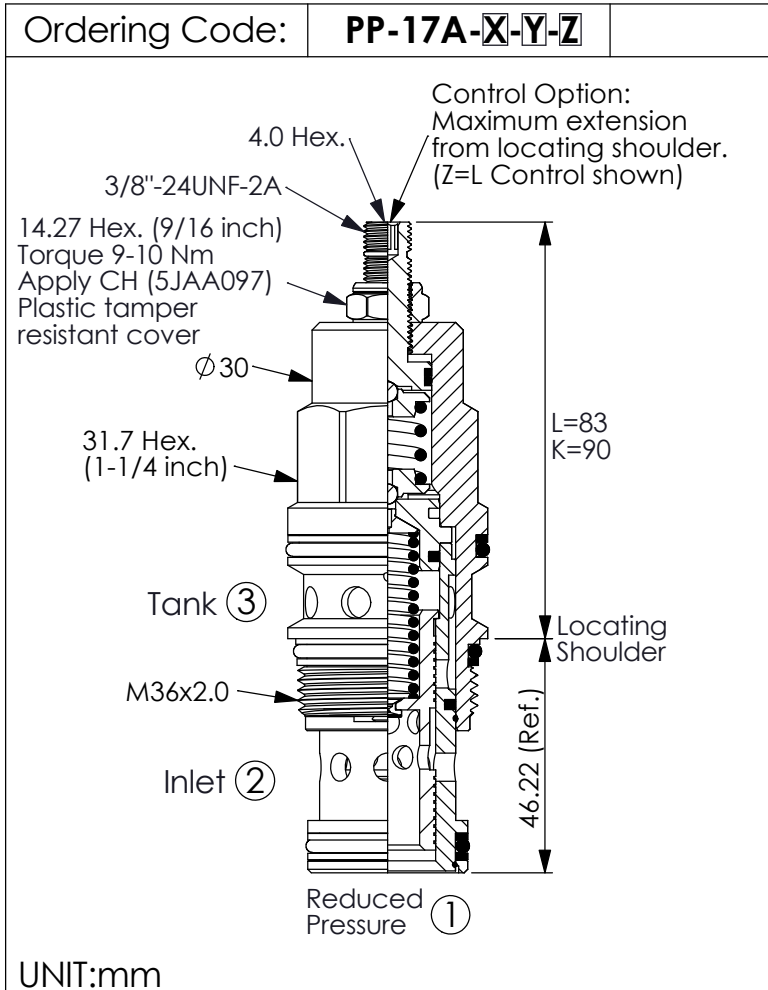
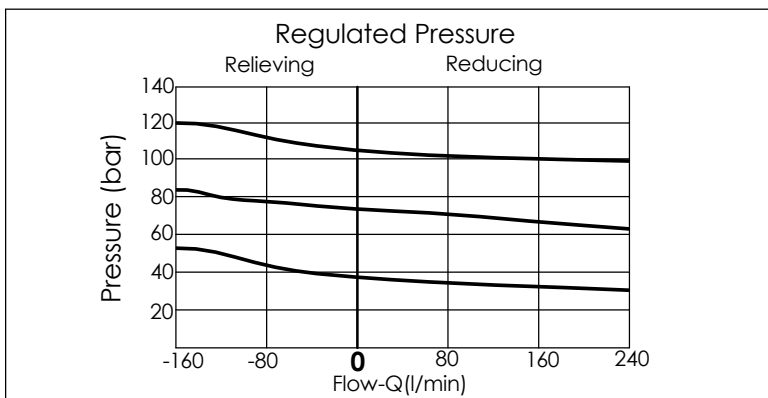

X	OPERATION	
30	Standard type	Low leakage
*33	Very good pressure control	Improved dynamic response
35	Impact resistant type	Low leakage without filter

Y	SPRINGS	
	ADJUSTMENT RANGES (X=30)(X=35)	
A	7-210 bar (14 bar Standard Setting)	Maximum Differential=210 bar
B	3.5-105 bar (14 bar Standard Setting)	Maximum Differential=210 bar
C	10.5-420 bar (14 bar Standard Setting)	
D	1.7-55 bar (14 bar Standard Setting)	Maximum Differential=140 bar
E	1.7-28 bar (14 bar Standard Setting)	Maximum Differential=140 bar
H	2-210 bar (14 bar Standard Setting)	Maximum Differential=210 bar
N	4-55 bar (14 bar Standard Setting)	Maximum Differential=140 bar
Q	4-28 bar (14 bar Standard Setting)	Maximum Differential=140 bar
W	10.5-315 bar (14 bar Standard Setting)	

* When X = 33, the lowest pressure will be a bit higher than standard.
· Any technical questions, please feel free to consult with our sales dept.

Z	OPTIONS	
L	Leakproof hex. socket screw.	
K	Handknob with Lock Knob. (Order Code: 6ZAK001)	