

Ordering Code: **RD-08W-X-Y-Z-1**

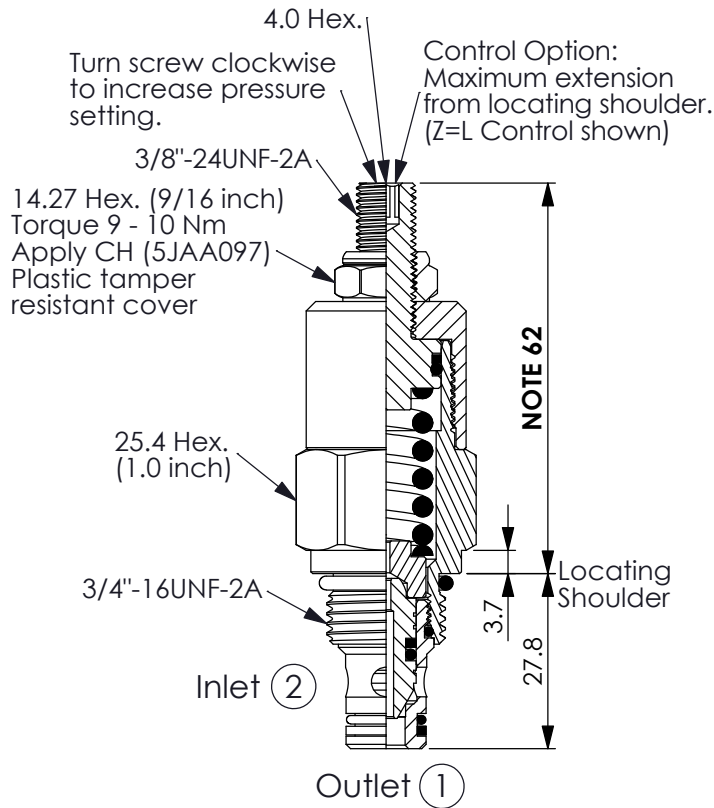

UNIT:mm

Illustrations / detail are for reference only. Data subject to change.

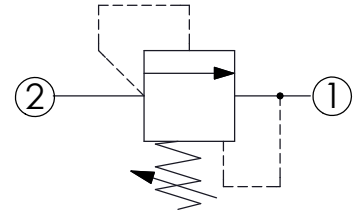

TECHNICAL DATA

Max. pressure:	240	bar
Rated flow:	30	l/min
Cavity-Tooling:	08W-2	
Installation torque:	25 - 35	Nm
Weight:	0.184	kg

Will accept maximum pressure at port ① but it is necessary to install double back-up rings to valve for cross port relief circuit application. If you have any questions, please contact Winner's sales department.

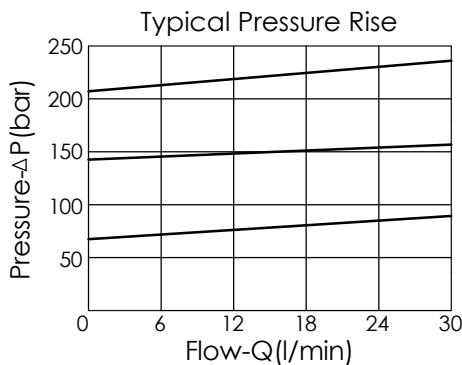

X OPERATION

2A ② to ① (P to T)

- Response Time-Typical (2 ms)
- Maximum Leakage Approximately (5 drops/min. to 85% of nominal setting)
- Dirt tolerant

Y PRESSURE SETTING

A 17 - 210 bar (70 bar Standard Setting)

Z OPTIONS

L Leakproof hex. socket screw.

