

Ordering Code: **RV-2A-X-Y-Z**

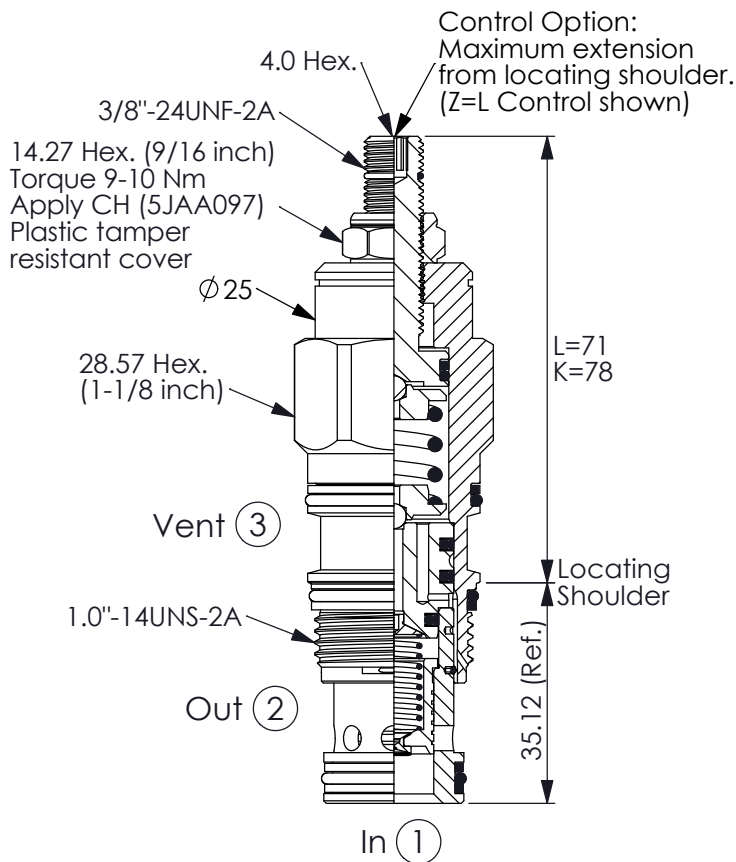

UNIT:mm

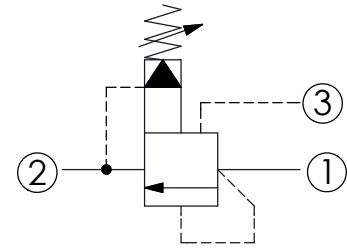

### TECHNICAL DATA

Max. Operating pressure:	350 bar
Rated flow:	120 l/min
Cavity-Tooling:	2A-3
Installation torque:	60-70 Nm
Weight:	0.28 (Z=L) kg

Will accept maximum pressure at port (2); suitable for use in cross port relief circuits. If used in cross port relief circuits, consider spool leakage.

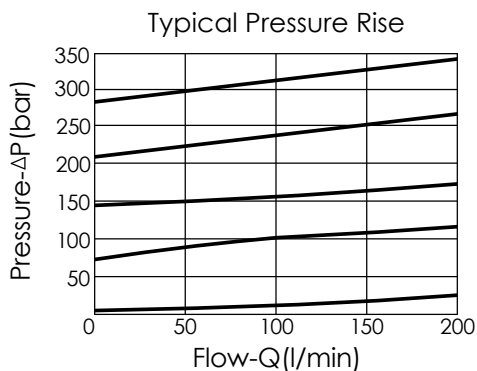

### X OPERATION

**30** Standard Type

- Response Time-Typical (10 ms)
- Maximum Leakage Approximately (50 cc/min./70 bar)

### Y SPRINGS

#### ADJUSTMENT RANGES

<b>A</b>	7-210 bar (70 bar Standard Setting)
<b>B</b>	3.5-105 bar (70 bar Standard Setting)
<b>C</b>	10.5-420 bar (70 bar Standard Setting)
<b>D</b>	1.7-55 bar (28 bar Standard Setting)
<b>E</b>	1.7-28 bar (14 bar Standard Setting)
<b>H</b>	2-210 bar (70 bar Standard Setting)
<b>W</b>	10.5-315 bar (70 bar Standard Setting)

### Z OPTIONS

**L** Leakproof hex. socket screw.

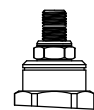

**K** Handknob with Lock Knob.  
(Order Code: 6ZAK001)

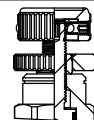

**C** Stainless Steel Tamper Resistant Cover.

