

(Ventable, balanced piston relief main stage with integral 8A control cavity)

Ordering Code: **RV-19A-X-Y-8**

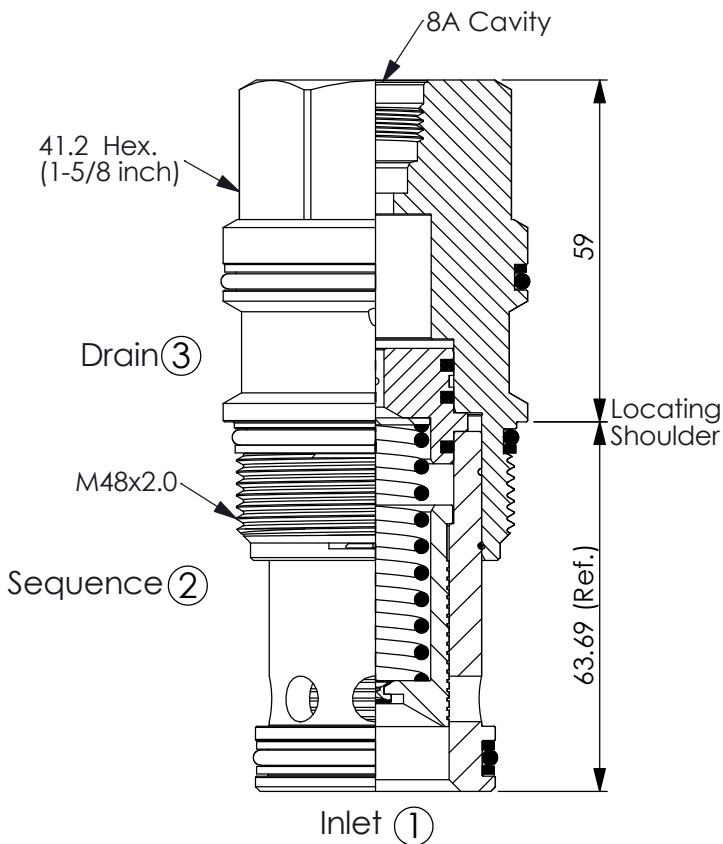

UNIT:mm

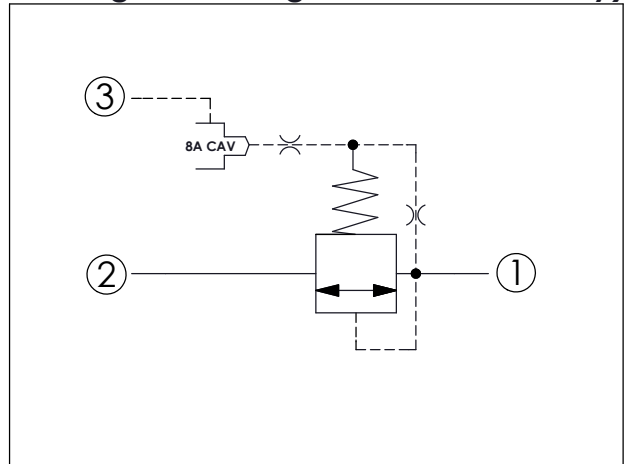

TECHNICAL DATA

Max. Operating pressure:	350	bar
Rated flow:	480	l/min
Cavity-Tooling:	19A-3 (19AB-3)	
Installation torque:	465-500	Nm
Weight:	1.19	kg

Will accept maximum pressure at port (2) ; suitable for use in cross port relief circuits. If used in cross port relief circuits, consider spool leakage.

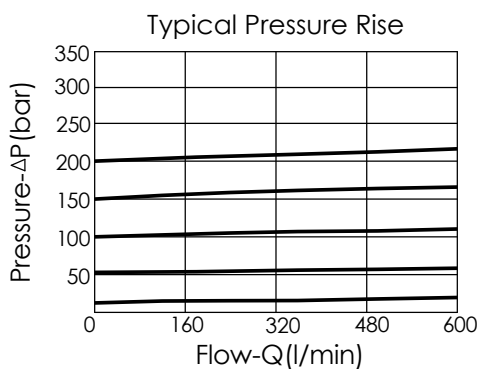

X OPERATION

30 Standard Type

- Response Time-Typical (10 ms)
- Maximum Leakage Approximately (82 cc/min./70 bar)

Y

SPRINGS

MINIMUM CONTROL PRESSURE

D

1.7 bar (25 psi)

W

7 bar (100 psi)

W spring is suit for higher pressure drop application. Please consult our sales department.