

SEQUENCE VALVE (Direct Acting without Reverse Flow Check)

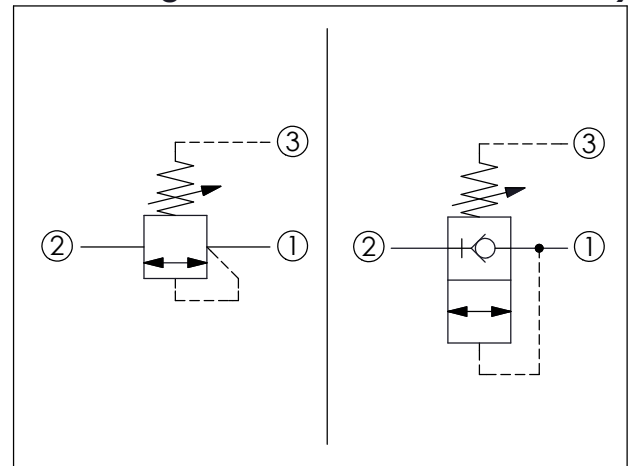

TECHNICAL DATA

Max. Operating pressure:	350 bar
Rated flow:	480 l/min
Cavity-Tooling:	19A-3 (19AB-3)
Installation torque:	465 - 500 Nm
Weight:	1.578 (Z=L) kg

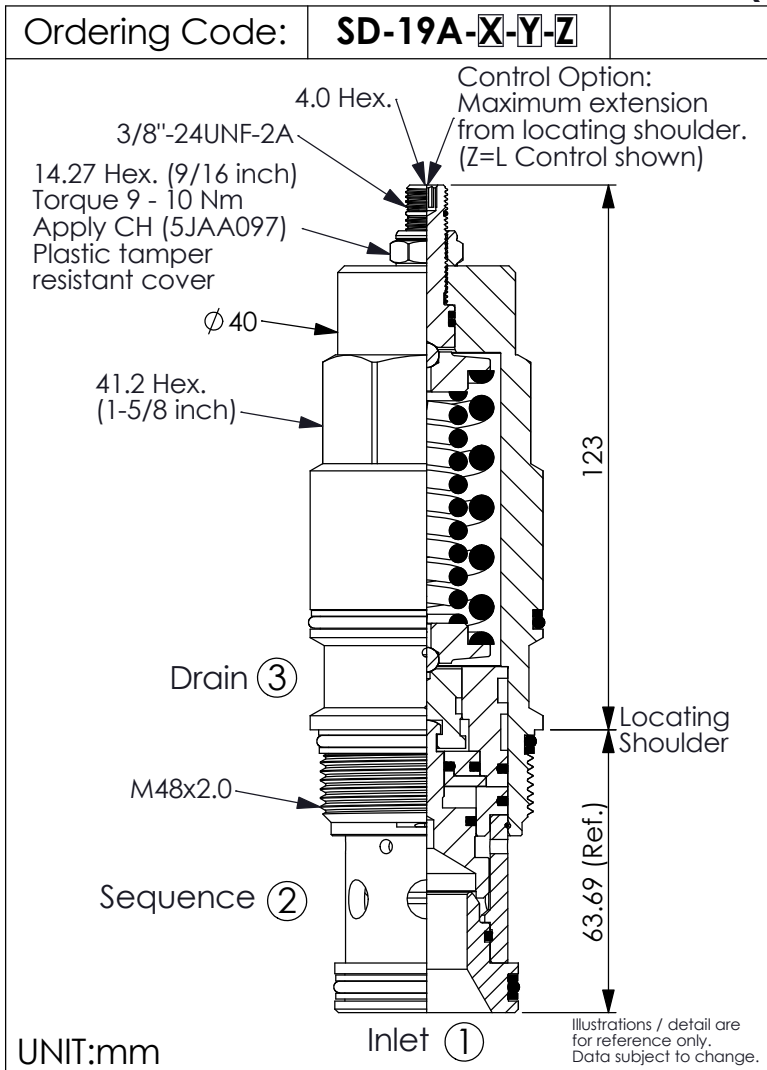
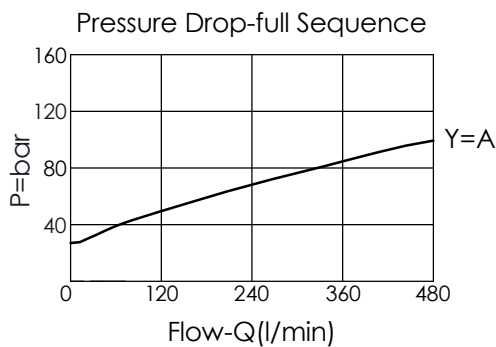

X OPERATION

30 Standard Type

- Response Time-Typical (2 ms)
- Maximum Leakage Approximately (0.7 cc/min.)

Y

SPRINGS

ADJUSTMENT RANGES

A	35 - 210 bar (70 bar Standard Setting)
B	20 - 105 bar (70 bar Standard Setting)
C	140 - 420 bar (140 bar Standard Setting)
D	14 - 55 bar (28 bar Standard Setting)
E	7 - 28 bar (14 bar Standard Setting)
W	55 - 315 bar (70 bar Standard Setting)

Z

OPTIONS

L	Leakproof hex. socket screw.	
C	Stainless Steel Tamper Resistant Cover.	
K	Handknob with Lock Knob. (Order Code: 6ZAK001)	