

SEQUENCE VALVE (Pilot Operated, Balanced Piston)

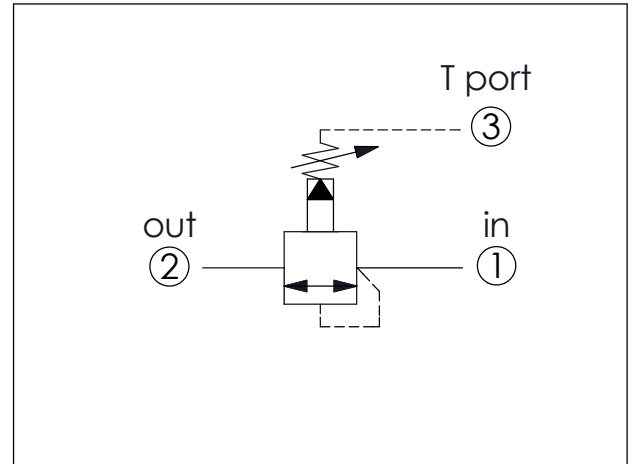

TECHNICAL DATA

Max. Operating pressure:	350	bar
Rated flow:	240	l/min
Cavity-Tooling:	17A-3	
Installation torque:	200-215	Nm
Weight:	0.62 (Z=L)	kg
· Maximum Leakage Approximately (66 cc/min./70 bar)		

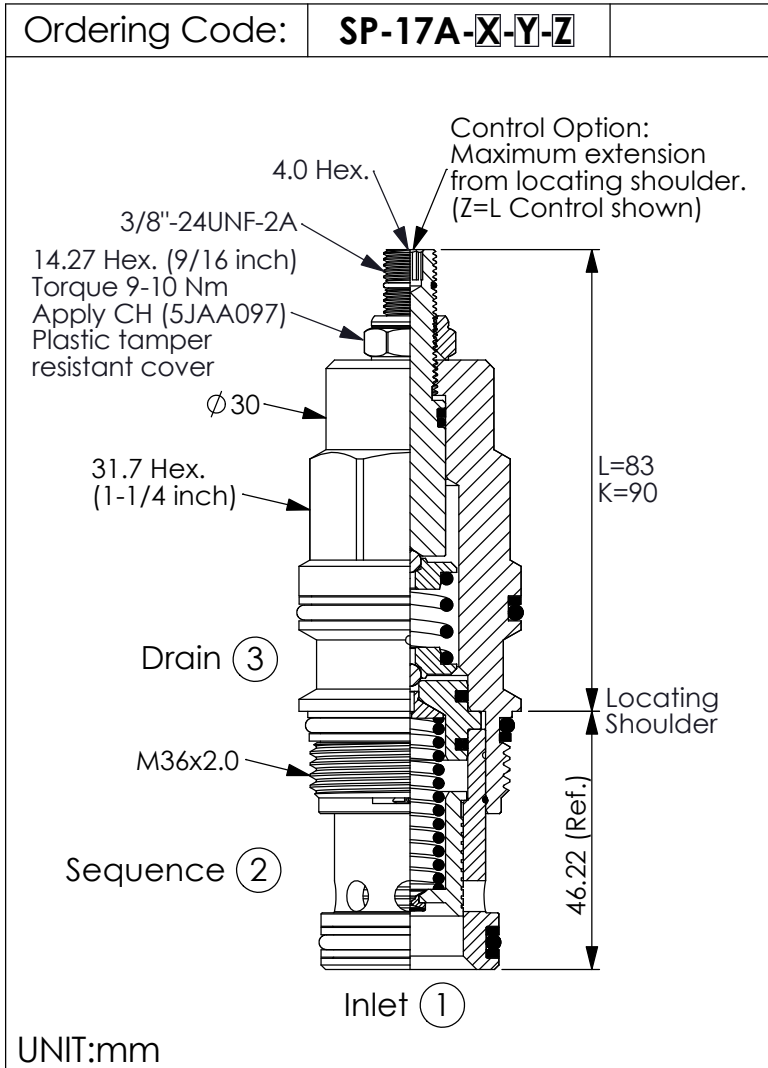
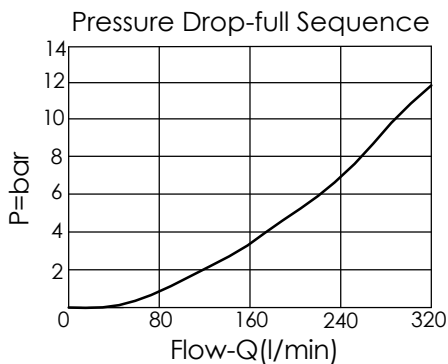

X	OPERATION	
30	Standard Type	

Y	SPRINGS	
	ADJUSTMENT RANGES	
A	7-210 bar	(70 bar Standard Setting)
B	3.5-105 bar	(70 bar Standard Setting)
C	10.5-420 bar	(70 bar Standard Setting)
D	1.7-55 bar	(28 bar Standard Setting)
E	1.7-28 bar	(14 bar Standard Setting)
N	4-55 bar	(28 bar Standard Setting)
Q	4-28 bar	(14 bar Standard Setting)
W	10.5-315 bar	(70 bar Standard Setting)

Z	OPTIONS	
L	Leakproof hex. socket screw.	
K	Handknob with Lock Knob. (Order Code: 6ZAK001)	
C	Stainless Steel Tamper Resistant Cover.	