

SEQUENCE VALVE (Pilot Operated, Balanced Poppet)

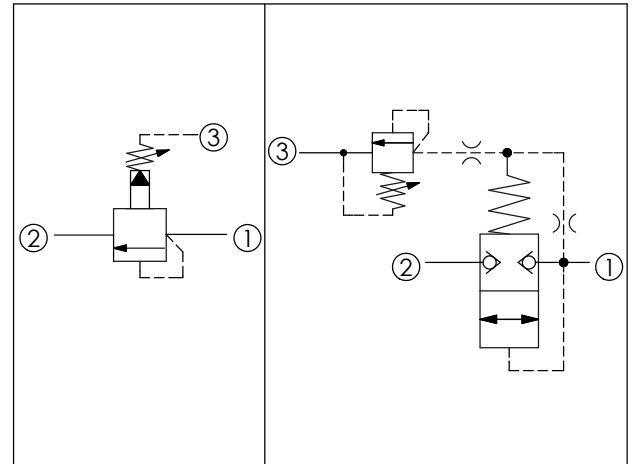

TECHNICAL DATA

Max. Operating pressure:	350 bar
Rated flow:	240 l/min
Cavity-Tooling:	17A-3
Installation torque:	200-215 Nm
Weight:	0.63 (Z=L) kg

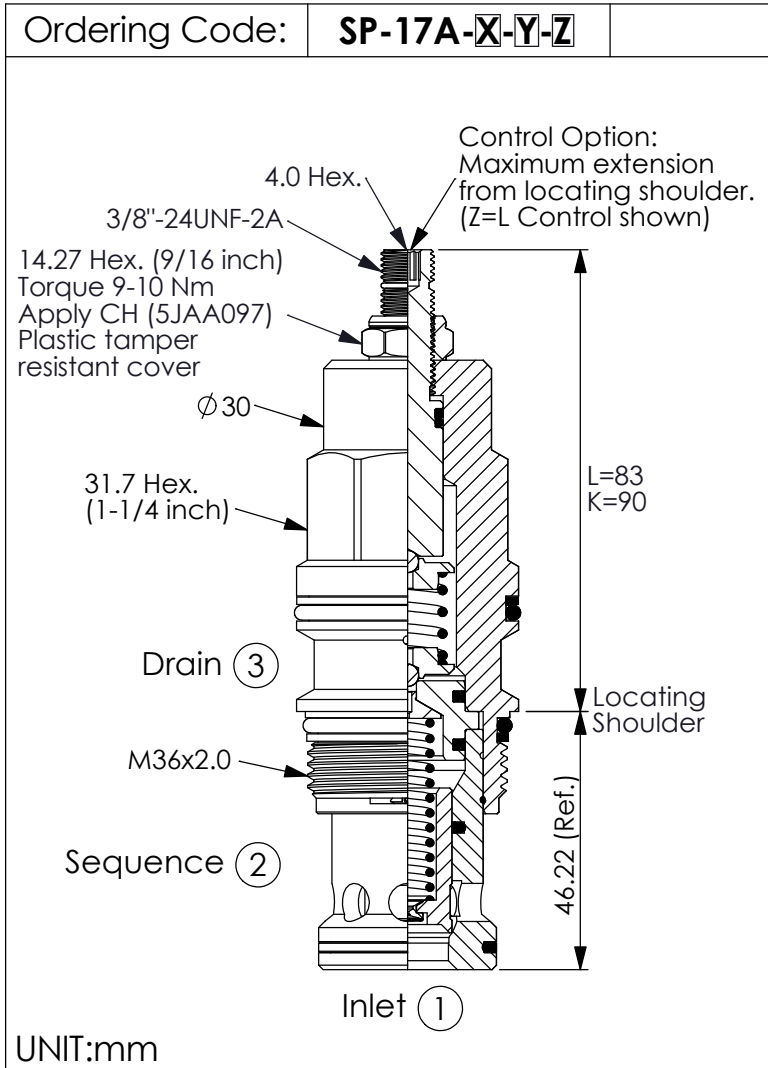
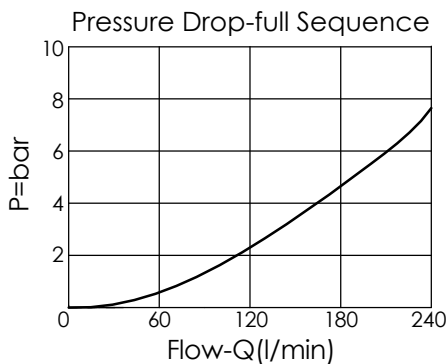

X OPERATION

3G Balanced Poppet

- Dirt tolerant
- Maximum Leakage Approximately (0.7 cc/min./70 bar)
- If the pressure drop of relief valve is high, it easily occurs cavitation which cause noise and manifold erosion. In order to improve this situation, please select balanced poppet structure.

Y

SPRINGS

ADJUSTMENT RANGES

A	7-210 bar (70 bar Standard Setting)
B	3.5-105 bar (70 bar Standard Setting)
C	10.5-420 bar (70 bar Standard Setting)
N	4-55 bar (28 bar Standard Setting)
Q	4-28 bar (14 bar Standard Setting)
W	10.5-315 bar (70 bar Standard Setting)

Z

OPTIONS

L	Leakproof hex. socket screw.	
K	Handknob with Lock Knob. (Order Code: 6ZAK001)	
C	Stainless Steel Tamper Resistant Cover.	