

SEQUENCE VALVE (Pilot Operated, Kick-down)

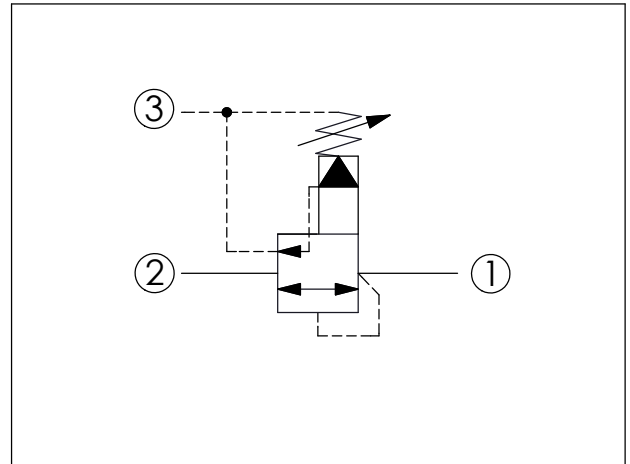
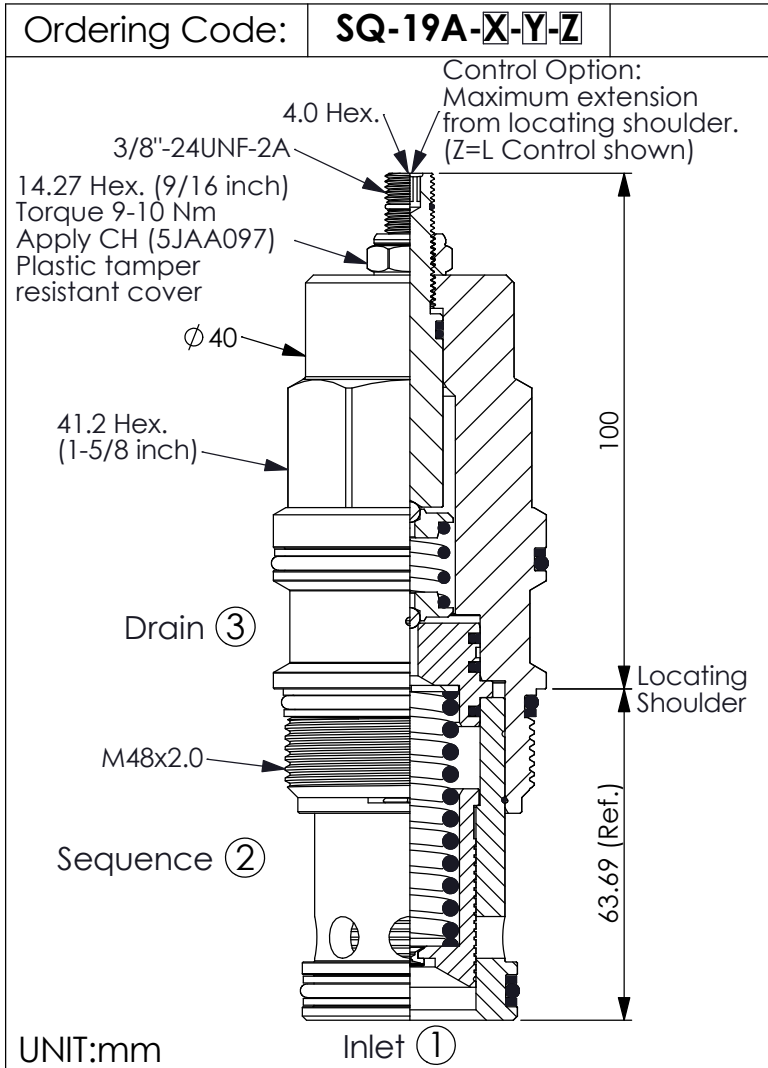

TECHNICAL DATA

Max. Operating pressure:	350	bar
Rated flow:	480	l/min
Cavity-Tooling:	19A-3 (19AB-3)	
Installation torque:	465-500	Nm
Weight:	1.42 (Z=L)	kg

This valve is a special type pressure control valve. When the inlet port is lower than pressure setting, the valve will remain close. The valve goes full open if the setting pressure is reached. Even if the pressure of sequence port makes the pressure drop be lower than setting pressure and the valve remains open status, the flow has to be stopped so as to make the valve reset and close.

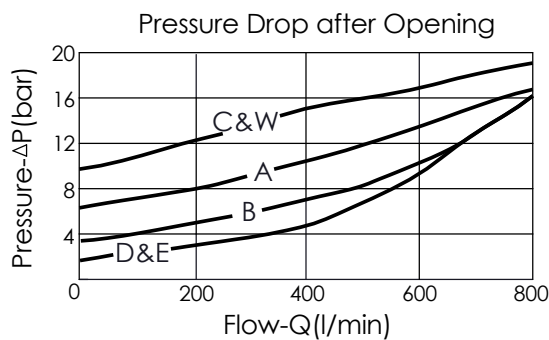

X OPERATION

30 Standard Type

- Response Time-Typical (25 ms)
- Maximum Leakage Approximately (80 cc/min./70 bar)

Y

SPRINGS

ADJUSTMENT RANGES

A	7-210 bar (70 bar Standard Setting)
B	3.5-105 bar (70 bar Standard Setting)
C	10.5-420 bar (70 bar Standard Setting)
D	1.7-55 bar (28 bar Standard Setting)
E	1.7-28 bar (14 bar Standard Setting)
W	10.5-315 bar (70 bar Standard Setting)

Z

OPTIONS

L	Leakproof hex. socket screw.	
K	Handknob with Lock Knob. (Order Code: 6ZAK001)	
C	Stainless Steel Tamper Resistant Cover.	