

Ordering Code: **EC-04H-X-Y-Z-D300**

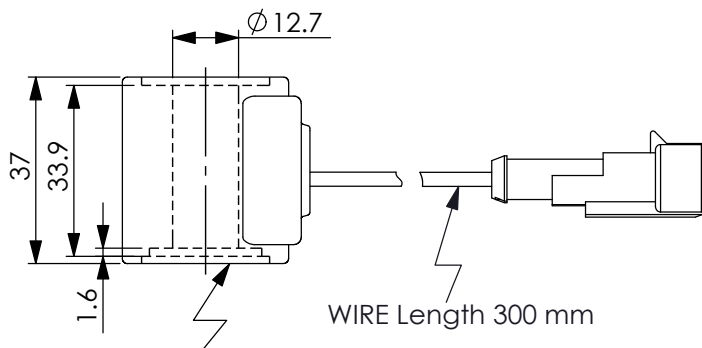

While installing, please be sure that this side is toward to the solenoid cartridge valve.

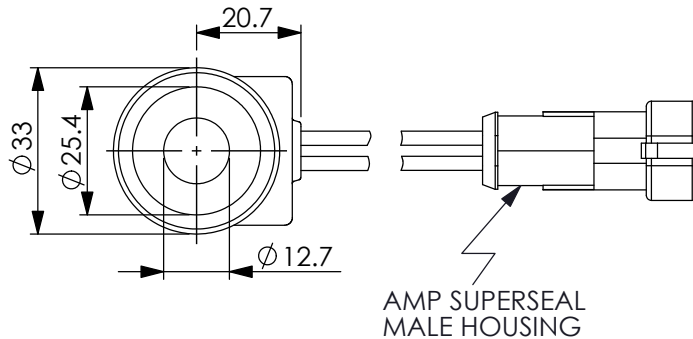

Illustrations / detail are for reference only. Data subject to change.

UNIT:mm

TECHNICAL DATA

Weight: 0.14 kg

HEAT INSULATION CLASS H:
356°F (180°C)

Ambient temperature range:
-22+140°F (-30+60°C)

Available on request:
Different Voltages -
Different connectors.

Inlet voltage fluctuations must not exceed $\pm 10\%$ of nominal voltage to obtain correct operation and long life of coils.

CE approved

X	Power (W)	Y	Connections
147	14.7 Watt.	C	DOUBLE LEAD (L)

Z	Voltage (V)	Resistance (Ω)	Current (A)	
	Nominal	20~25 °C	Cold Coil	Hot Coil
E	12V DC	9.8 \pm 7%	1.22	0.83
D	24V DC	39.3 \pm 7%	0.62	0.41