

Ordering Code: **EC-19A-X-Y-Z**

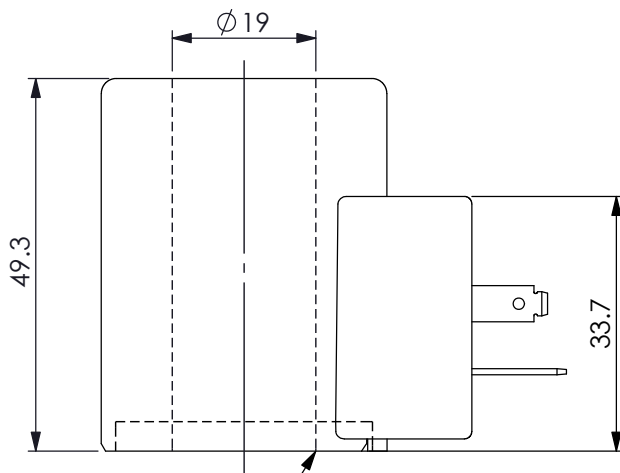

While installing, please be sure that this side is toward to the solenoid cartridge valve.

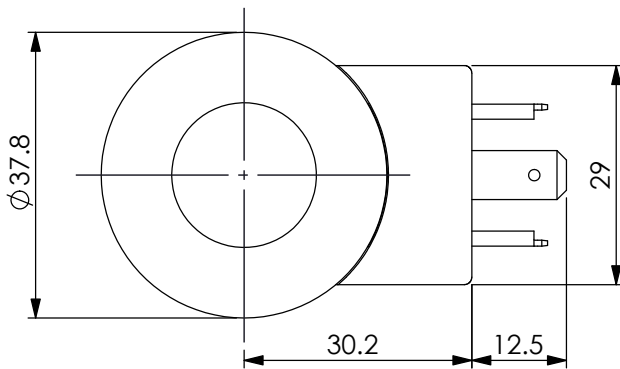
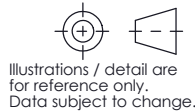

UNIT:mm

Illustrations / detail are for reference only. Data subject to change.

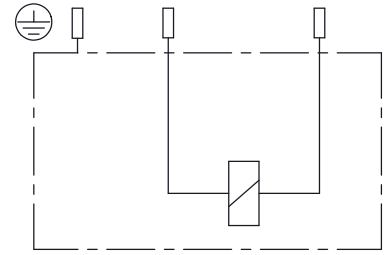

TECHNICAL DATA

Weight: 0.24 kg

HEAT INSULATION CLASS H:
356°F | (180°C)

Ambient temperature range:
-22+140°F | (-30+60°C)

Available on request:
Different Voltages -
Different connectors.

Inlet voltage fluctuations must not exceed $\pm 10\%$ of nominal voltage to obtain correct operation and long life of coils.

Connector Environment Rating: IP65

X	Nominal Power (W) (At rated voltage)	
220	22 Watt.	
*The nominal power (W) at maximum current with proportional control is 9 watt.		

Y	Connections	
H	Connessione A EN 175301-803 ISO 4400 (DIN 43650)	

Z	Voltage (V)	Resistance (Ω)	Maximum Current (A) (Proportional Control)
	Nominal	20~25 °C	
E	12V DC	6.4 \pm 8%	1150 mA
D	24V DC	26.2 \pm 5%	590 mA