

Ordering Code: **MH03PBC-X-Y-Z01**

Stack Height : 44.5mm

UNIT:mm

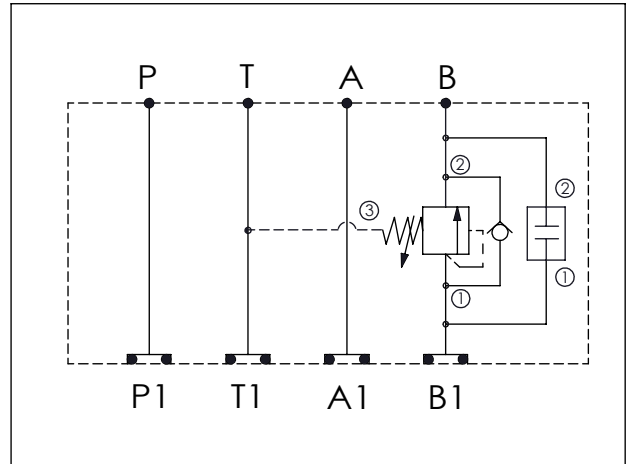

### TECHNICAL DATA

Aluminum Body Pressure Rating: 210 bar

Ductile Iron  
Body Pressure Rating: 350 bar

Rated flow: 40 l/min

Cartridge Valve:  
Refer to CP13A-Y-Z  
SC11A-X-Y-Z

\* Refer to Winner Cartridge Valves Catalog.

Aluminum	0.46 kg(WITHOUT VALVES) 0.71 kg(INCLUDE VALVES)
Ductile Iron	1.33 kg(WITHOUT VALVES) 1.58 kg(INCLUDE VALVES)

\* If you need the special specification.  
Please contact us.

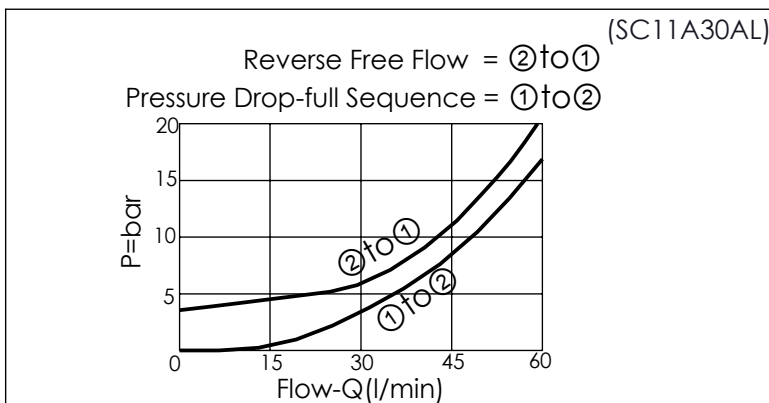

<b>X</b>	<b>SELECTION FOR CHECK VALVE</b>
<b>13A2</b>	CAVITY ONLY(WITHOUT VALVE)
<b>CP00</b>	CP13A2H00N (PLUG ONLY)
Please refer to the list price of cartridge program.	

<b>Y</b>	<b>SELECTION FOR B PORT CONTROL</b>
<b>11A3</b>	CAVITY ONLY(WITHOUT VALVE)
<b>SC0A</b>	SC11A30AL (60LPM , 35-210bar)
Please refer to the list price of cartridge program.	

<b>Z</b>	<b>BODY MATERIAL</b>
<b>A</b>	HIGH-STRENGTH ALUMINUM
<b>S</b>	DUCTILE IRON