

Ordering Code: MH03RAB-X-Y-Z01
Stack Height : 44.5mm

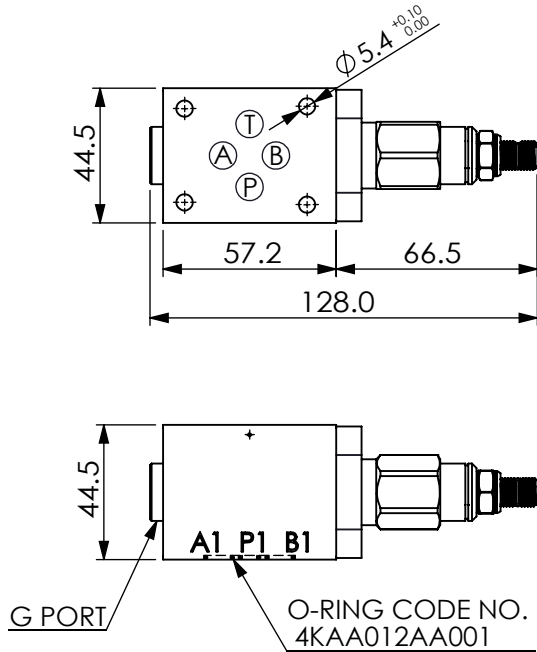

UNIT:mm

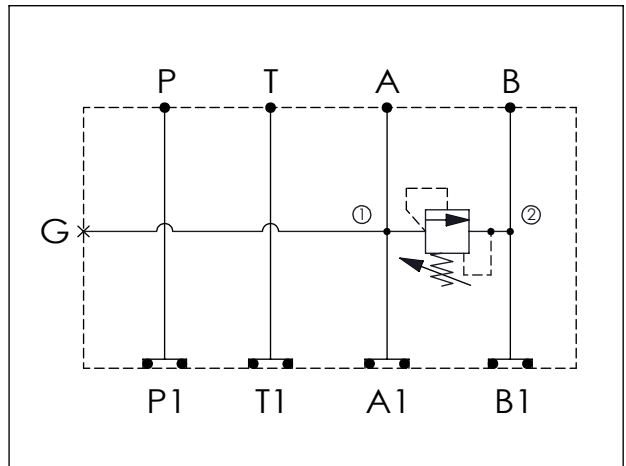

TECHNICAL DATA

Aluminum Body Pressure Rating: 210 bar
 Ductile Iron
 Body Pressure Rating: 350 bar

Rated flow: 40 l/min

Cartridge Valve:
 Refer to RD10A-X-Y-Z
 * Refer to Winner Cartridge Valve Catalog.

Aluminum	0.28 kg(WITHOUT VALVE)
	0.45 kg(INCLUDE VALVE)
DUCTILE IRON	0.79 kg(WITHOUT VALVE)
	0.96 kg(INCLUDE VALVE)

* If you need the special specification.
 Please contact us.

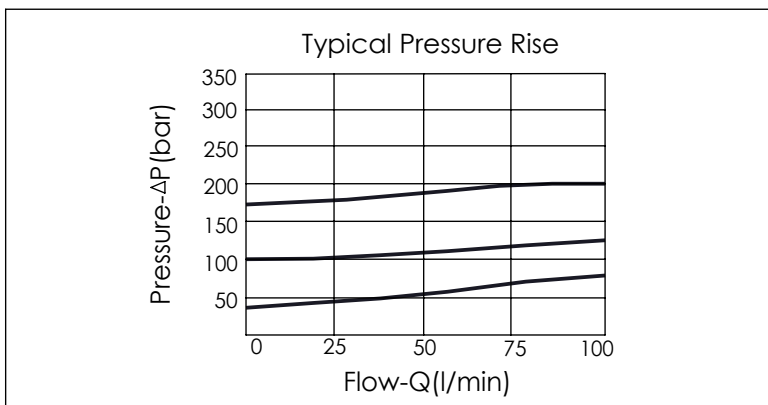

X	SELECTION FOR G PORT	
G02	G 1/4"(Metric)	
N02	NPT 1/4"(U.S. Units)	

Y	SELECTION FOR B PORT CONTROL
10A2	CAVITY ONLY(WITHOUT VALVE)
RD5A	RD10A25AL (95LPM,35-210bar)

Z	BODY MATERIAL	
A	HIGH-STRENGTH ALUMINUM	
S	DUCTILE IRON	

Please refer to the list price of cartridge program.