

Ordering Code: **MH05CAW-X-Y-Z 21**

Stack Height : 49.5mm

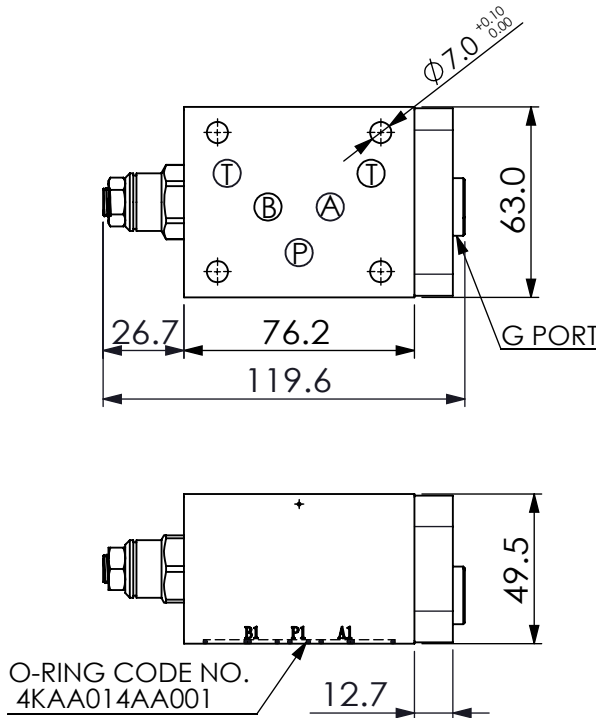

UNIT:mm

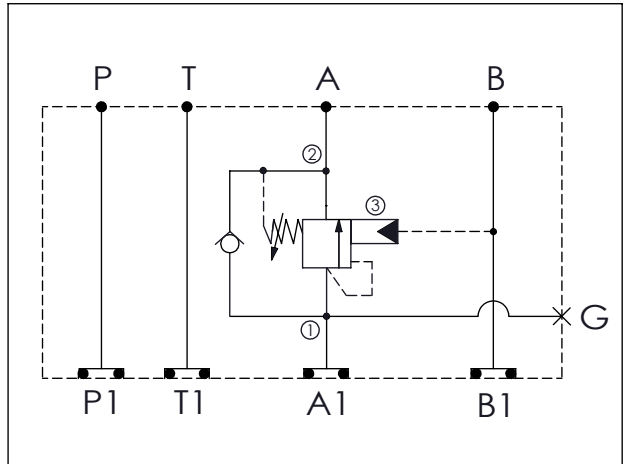
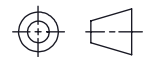

TECHNICAL DATA

Aluminum Body Pressure Rating: 210 bar
 Ductile Iron
 Body Pressure Rating: 350 bar

Rated flow: 60 l/min

Cartridge Valve:
 Refer to CB11A-X-Y-Z
 * Refer to Winner Cartridge Valve Catalog.

Aluminum	0.65 kg(WITHOUT VALVE) 0.85 kg(INCLUDE VALVE)
Ductile Iron	1.8 kg(WITHOUT VALVE) 2.0 kg(INCLUDE VALVE)

* If you need the special specification.
 Please contact us.

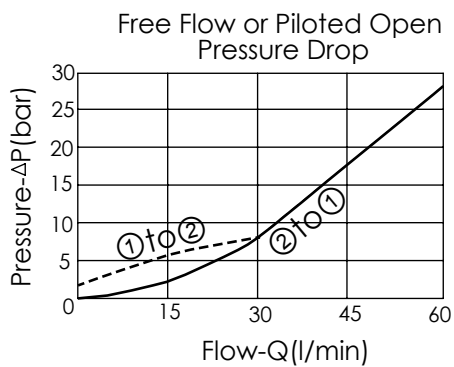

X SELECTION FOR G PORT

G02	G 1/4"(Metric)	
N02	NPT 1/4"(U.S. Units)	

Y SELECTION FOR B PORT CONTROL

11A3	CAVITY ONLY(WITHOUT VALVE)
CB3H	CB11A33HL (3:1 , 280bar)
CB4J	CB11A34JL (4.5:1 , 350bar)
CB0J	CB11A30JL (10:1 , 350bar)

Z BODY MATERIAL

A	HIGH-STRENGTH ALUMINUM	
S	DUCTILE IRON(Phosphatizing)	
E	DUCTILE IRON(Zinc-Nickel plating)	