

Ordering Code:	MH05CBT-X-Y-Z 03
Stack Height : 63.0mm	

O-RING CODE NO. 4KAA014AA001

UNIT:mm

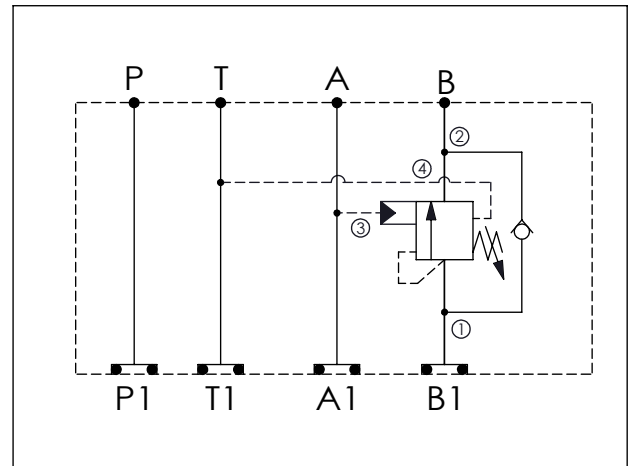

TECHNICAL DATA	
Aluminum Body Pressure Rating:	210 bar
Ductile Iron Body Pressure Rating:	350 bar
Rated flow:	80 l/min
Cartridge Valve: Refer to CW22A-X-Y-Z * Refer to Winner Cartridge Valve Catalog.	
Aluminum	1.1 kg(WITHOUT VALVE) 1.46 kg(INCLUDE VALVE)
Ductile Iron	3.1 kg(WITHOUT VALVE) 3.46 kg(INCLUDE VALVE)
* If you need the special specification. Please contact us.	

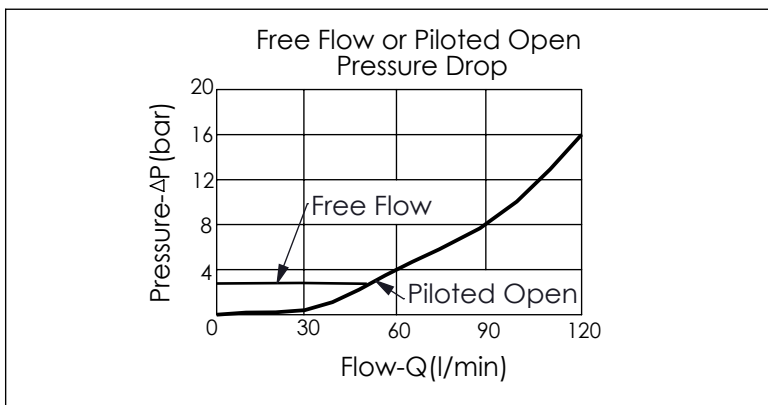

X	SELECTION FOR G PORT
N	WITHOUT PORT

Y	SELECTION FOR B PORT CONTROL
22A4	CAVITY ONLY(WITHOUT VALVE)
CWAI	CW22A4AIL (1:1 , 105bar)
CWBF	CW22A4BFL (2:1 , 175bar)
CWCH	CW22A4CHL (3:1 , 280bar)
CWEF	CW22A4EFL (5:1 , 175bar)

Z	BODY MATERIAL
A	HIGH-STRENGTH ALUMINUM
S	DUCTILE IRON

Please refer to the list price of cartridge program.