

Ordering Code: **MH05CBW-X-Y-Z 01**

Stack Height : 49.5mm

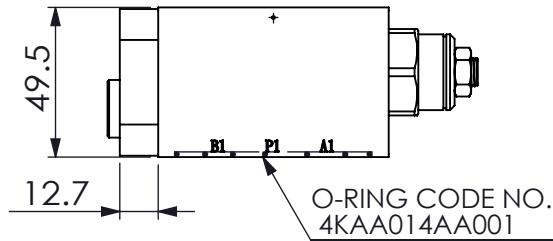

UNIT:mm

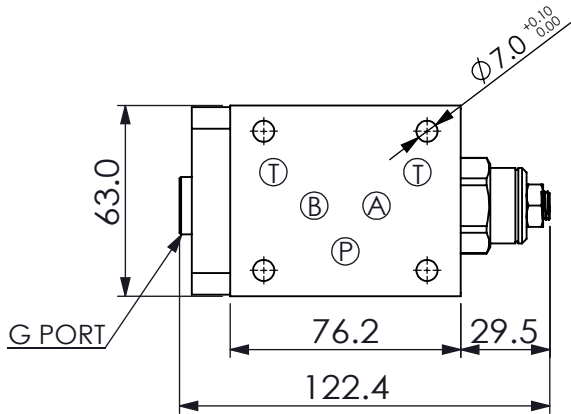
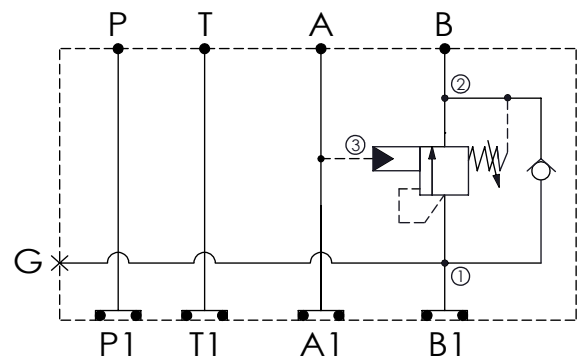

TECHNICAL DATA

Aluminum Body Pressure Rating: 210 bar
 Ductile Iron
 Body Pressure Rating: 350 bar

Rated flow: 80 l/min

Cartridge Valve:
 Refer to CB2A-X-Y-Z
 * Refer to Winner Cartridge Valve Catalog.

Aluminum	0.65 kg(WITHOUT VALVE) 1.05 kg(INCLUDE VALVE)
Ductile Iron	1.65 kg(WITHOUT VALVE) 2.05 kg(INCLUDE VALVE)

* If you need the special specification.
 Please contact us.

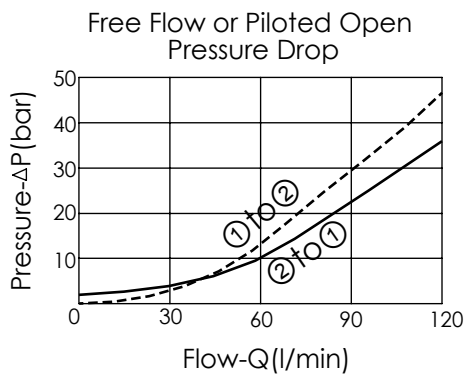

X SELECTION FOR A PORT CONTROL

2A3	CAVITY ONLY(WITHOUT VALVE)
CB3H	CB2A33HL (3:1 , 280bar)
CB4J	CB2A34JL (4.5:1 , 350bar)
CB0J	CB2A30JL (10:1 , 350bar)

Please refer to the list price of cartridge program.

Y SELECTION FOR G PORT

G02	G 1/4"(Metric)
N02	NPT 1/4"(U.S. Units)

Z BODY MATERIAL

A	HIGH-STRENGTH ALUMINUM
S	DUCTILE IRON(Phosphatizing)
E	DUCTILE IRON(Zinc-Nickel plating)