

Ordering Code: **MH05FBI-X-Y-Z01**

Stack Height : 49.5mm

Dimensions:  
 Total length: 172.5 mm  
 Distance from inlet to valve: 96.3 mm  
 Distance from valve to ports: 76.2 mm  
 Height: 63.0 mm  
 Stack Height: 49.5 mm  
 Port diameter:  $\phi 7.0^{+0.10}_{0.00}$

Ports: P, T, A, B (top view); P1, T1, A1, B1 (bottom view)

O-RING CODE NO. 4KAA014AA001

UNIT:mm

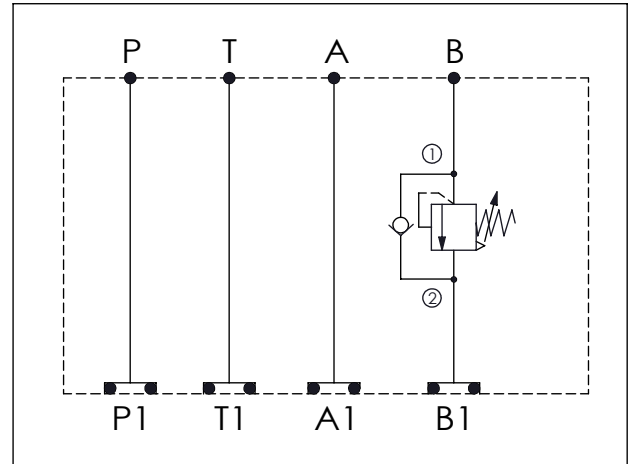

TECHNICAL DATA	
Aluminum Body Pressure Rating:	210 bar
Ductile Iron Body Pressure Rating:	350 bar
Rated flow:	80 l/min
Cartridge Valve: Refer to SC5A-X-Y-Z	
* Refer to Winner Cartridge Valves Catalog.	
Aluminum	0.6 kg(WITHOUT VALVE) 0.98 kg(INCLUDE VALVE)
Ductile Iron	1.76 kg(WITHOUT VALVE) 2.14 kg(INCLUDE VALVE)
* If you need the special specification. Please contact us.	

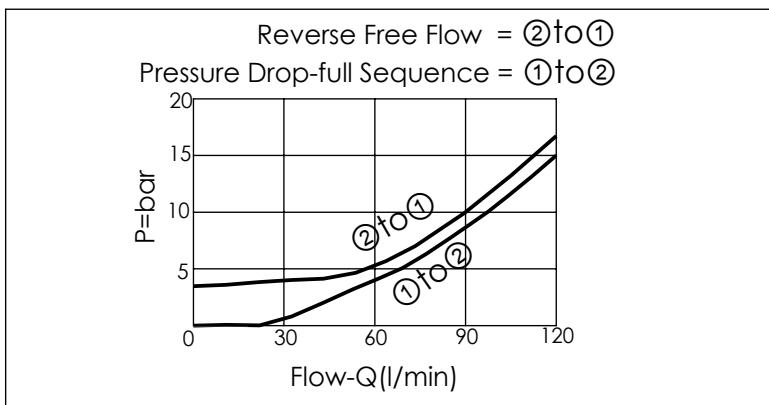

X	SELECTION FOR A PORT CONTROL
N	WITHOUT PORT

Y	SELECTION FOR B PORT CONTROL
<b>5A2</b>	CAVITY ONLY(WITHOUT VALVE)
<b>SC0A</b>	SC5A20AL (120LPM,35-210bar)
<b>SC0B</b>	SC5A20BL (120LPM,20-105bar)

Z	BODY MATERIAL
<b>A</b>	HIGH-STRENGTH ALUMINUM
<b>S</b>	DUCTILE IRON

Please refer to the list price of cartridge program.