

ISO 05 SANDWICH MANIFOLD

Ordering Code: **MH05PAC-X-Y-Z03**

Stack Height : 63.0mm

UNIT:mm

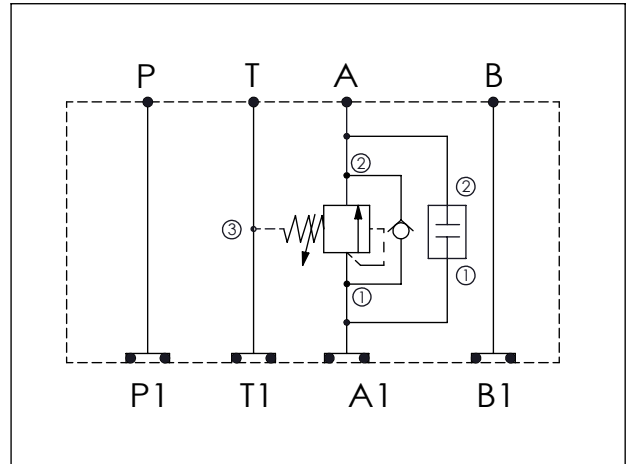

TECHNICAL DATA

Aluminum Body Pressure Rating: 210 bar
 Ductile Iron Body Pressure Rating: 350 bar

Rated flow: 80 l/min

Cartridge Valve:
 Refer to CP5A-Y-Z
 SC2A-X-Y-Z

* Refer to Winner Cartridge Valves Catalog.

Aluminum	0.92 kg(WITHOUT VALVES) 1.42 kg(INCLUDE VALVES)
Ductile Iron	2.65 kg(WITHOUT VALVES) 3.15 kg(INCLUDE VALVES)

* If you need the special specification. Please contact us.

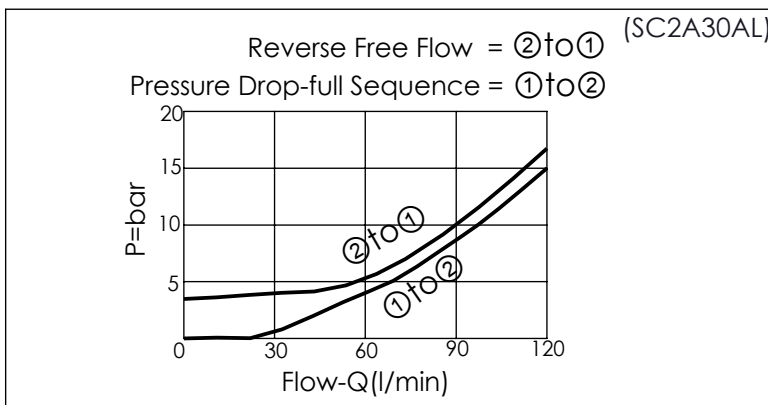

X	SELECTION FOR CHECK VALVE
5A2	CAVITY ONLY(WITHOUT VALVE)
CP00	CP5A2H00N (PLUG ONLY)
Please refer to the list price of cartridge program.	

Y	SELECTION FOR B PORT CONTROL
2A3	CAVITY ONLY(WITHOUT VALVE)
SC0A	SC2A30AL (120LPM , 35-210bar)

Z	BODY MATERIAL
A	HIGH-STRENGTH ALUMINUM
S	DUCTILE IRON

Please refer to the list price of cartridge program.