

Ordering Code: **MH05PPW-X-Y-Z 01**

Stack Height : 49.5mm

Technical drawing showing dimensions and port labels:

- Overall length: 152.4 mm
- Distance from left face to center of P1: 76.2 mm
- Distance from center of P1 to center of T1: 72.2 mm
- Height: 63.0 mm
- Stack Height: 49.5 mm
- Port diameters:  $\phi 7.0^{+0.10/0.00}$
- Ports: P, T, A, B (top); P1, T1, A1, B1 (bottom)
- G PORT (side)
- O-RING CODE NO. 4KAA014AA001

UNIT:mm

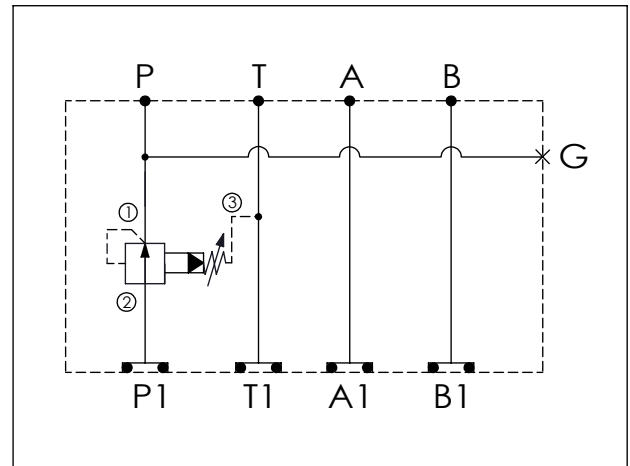

### TECHNICAL DATA

Aluminum Body Pressure Rating: 210 bar  
 Ductile Iron  
 Body Pressure Rating: 350 bar

Rated flow: 80 l/min

Cartridge Valve:  
 Refer to PB2A-X-Y-Z  
 \* Refer to Winner Cartridge Valve Catalog.

Aluminum	0.65 kg(WITHOUT VALVE)
	0.93 kg(INCLUDE VALVE)
Ductile Iron	1.9 kg(WITHOUT VALVE)
	2.25 kg(INCLUDE VALVE)

\* If you need the special specification.  
 Please contact us.

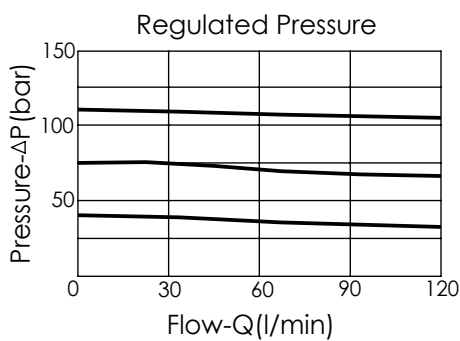

### X SELECTION FOR P PORT CONTROL

**2A3** CAVITY ONLY (WITHOUT VALVE)

**PBOA** PB2A30AL(80LPM,7-210bar)  
 (Pilot Operated Reducing)

Please refer to the list price of cartridge program.

### Y SELECTION FOR G PORT

**G02** G 1/4"(Metric)

**N02** NPT 1/4"(U.S. Units)

### Z BODY MATERIAL

**A** HIGH-STRENGTH ALUMINUM

**S** DUCTILE IRON