

## ISO 05 SANDWICH MANIFOLD

Ordering Code: <b>MH05RBA-X-Y-Z01</b>
Stack Height : 49.5mm

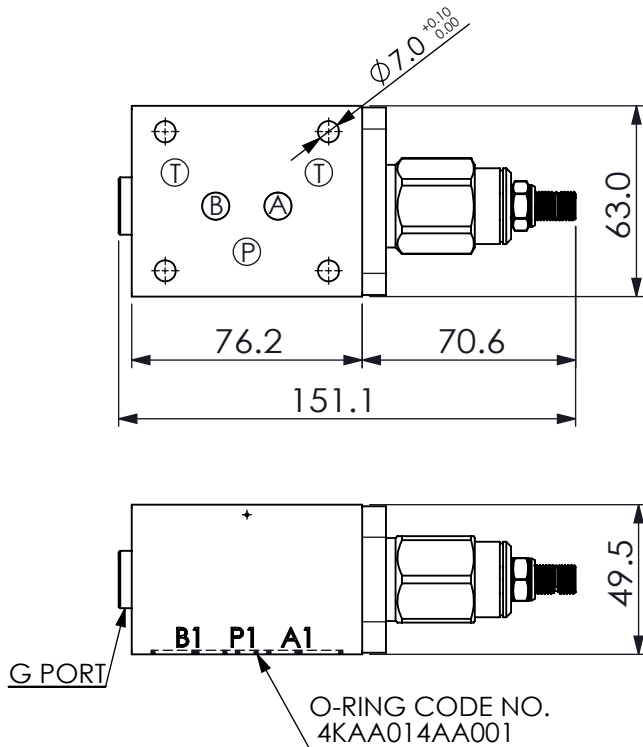

UNIT:mm

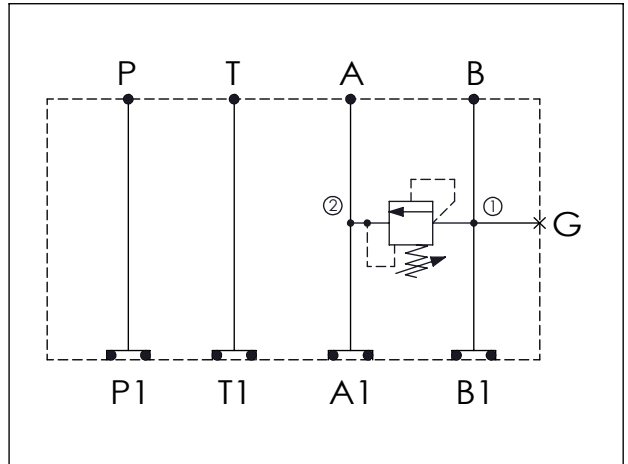

### TECHNICAL DATA

Aluminum Body Pressure Rating: 210 bar  
 Ductile Iron  
 Body Pressure Rating: 350 bar

Rated flow: 80 l/min

Cartridge Valve:  
 Refer to RD3A-X-Y-Z  
 \* Refer to Winner Cartridge Valves Catalog.

Aluminum	0.56 kg(WITHOUT VALVE)
	0.86 kg(INCLUDE VALVE)

\* If you need the special specification.  
 Please contact us.

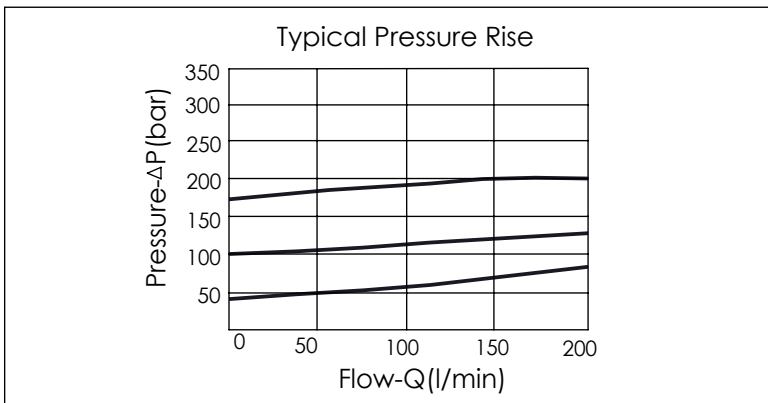

<b>X</b>	<b>SELECTION FOR A PORT CONTROL</b>
<b>3A2</b>	CAVITY ONLY(WITHOUT VALVE)
<b>RD5A</b>	RD3A25AL (200 LPM , 35-210bar)
Please refer to the list price of cartridge program.	

<b>Y</b>	<b>SELECTION FOR G PORT</b>
<b>G02</b>	G 1/4"(Metric)
<b>N02</b>	NPT 1/4"(U.S. Units)

<b>Z</b>	<b>BODY MATERIAL</b>
<b>A</b>	HIGH-STRENGTH ALUMINUM