

ISO 05 SANDWICH MANIFOLD

Ordering Code:	MH05RTH-X-Y-Z01
Stack Height :	49.5mm

UNIT:mm

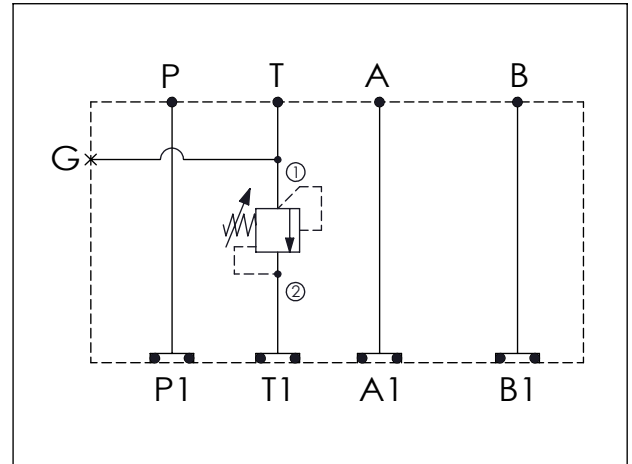

TECHNICAL DATA

Aluminum Body Pressure Rating: 210 bar
 Ductile Iron
 Body Pressure Rating: 350 bar
 Rated flow: 80 l/min

Cartridge Valve:
 Refer to RD3A-X-Y-Z
 * Refer to Winner Cartridge Valves Catalog.

Aluminum	0.74 kg(WITHOUT VALVE) 1.04 kg(INCLUDE VALVE)

* If you need the special specification.
 Please contact us.

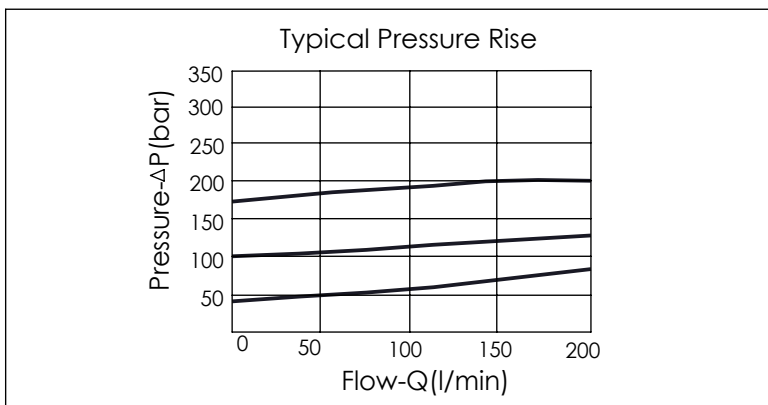

X	SELECTION FOR T PORT CONTROL
3A2	CAVITY ONLY(WITHOUT VALVE)
RD5A	RD3A25AL (200 LPM , 35-210bar)
Please refer to the list price of cartridge program.	

Y	SELECTION FOR G PORT
G02	G 1/4"(Metric)
N02	NPT 1/4"(U.S. Units)

Z	BODY MATERIAL
A	HIGH-STRENGTH ALUMINUM