

Ordering Code: **MH05B-SAO-X-Y-Z 03**

Stack Height : 63.0mm

O-RING CODE NO. 4KAA014AA001

O-RING CODE NO. 4KAA012AA001

UNIT:mm

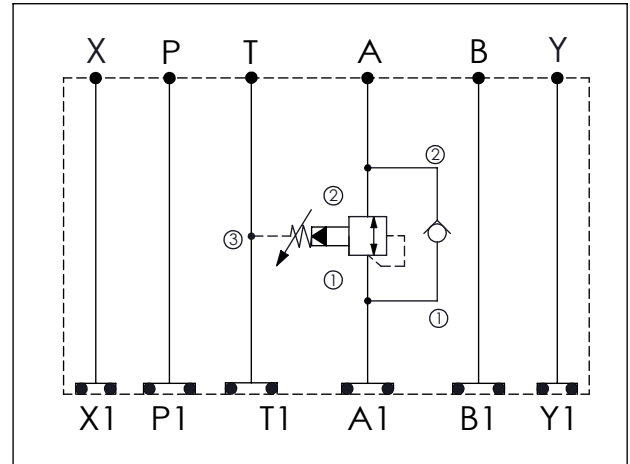

TECHNICAL DATA

Aluminum Body Pressure Rating: 210 bar
 Ductile Iron Body Pressure Rating: 350 bar

Rated flow: 80 l/min

Cartridge Valve:
 Refer to CV5A-X-Y-Z
 SP2A-X-Y-Z

* Refer to Winner Cartridge Valves Catalog.

Aluminum	0.92 kg(WITHOUT VALVES) 1.37 kg(INCLUDE VALVES)
Ductile Iron	2.71 kg(WITHOUT VALVES) 3.16 kg(INCLUDE VALVES)

* If you need the special specification. Please contact us.

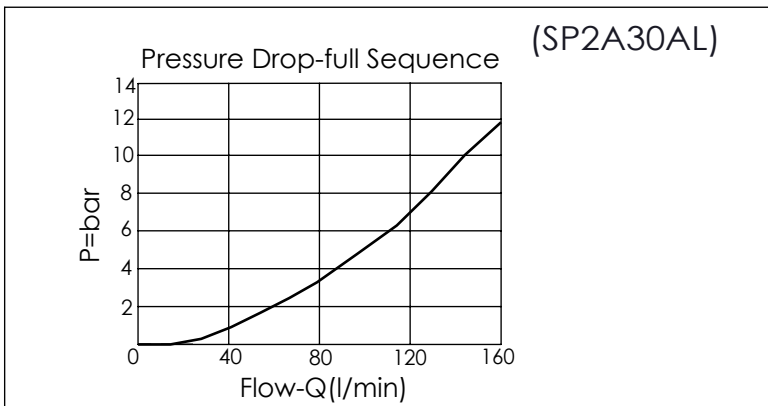

X	SELECTION FOR CHECK VALVE
5A2	CAVITY ONLY(WITHOUT VALVE)
CV2120	CV5A2120N (120LPM , 2.0bar)
Please refer to the list price of cartridge program.	

Y	SELECTION FOR B PORT CONTROL
2A3	CAVITY ONLY(WITHOUT VALVE)
SP0A	SP2A30AL (120LPM , 7-210bar)
Please refer to the list price of cartridge program.	

Z	BODY MATERIAL
A	HIGH-STRENGTH ALUMINUM
S	DUCTILE IRON