

Ordering Code: **ML-10W3-X-Y 01-Z**

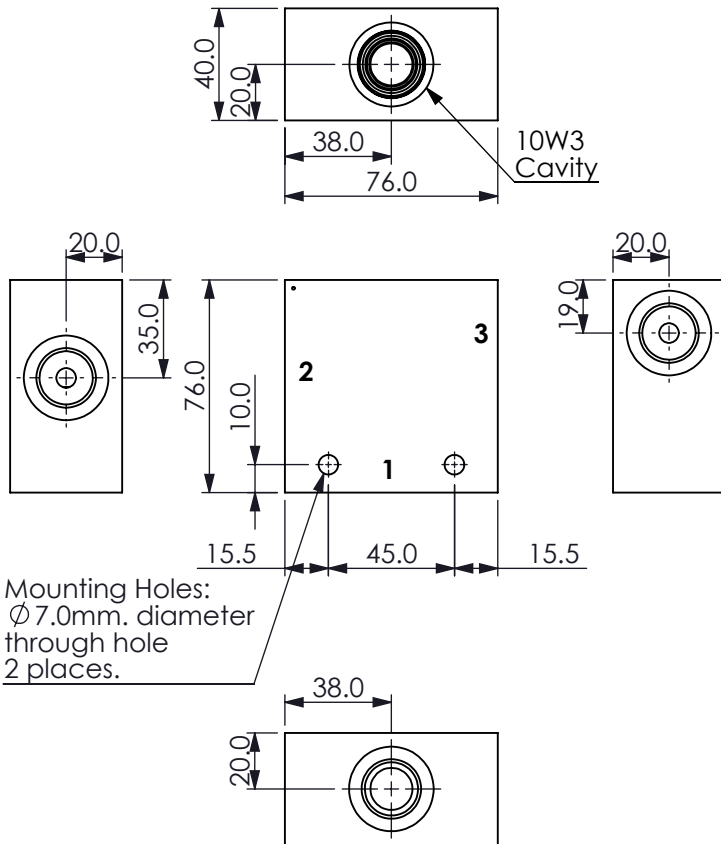

UNIT:mm

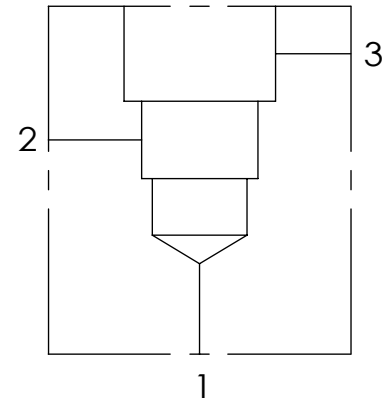
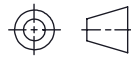

### TECHNICAL DATA

Aluminum Body Pressure Rating: 210 bar

Steel Body Pressure Rating: 350 bar

Cavity:

Refer to 10W3

\* Refer to Winner Cartridge Valve Catalog.

Aluminum	0.52 kg(WITHOUT VALVES)
----------	-------------------------

Steel	1.52 kg(WITHOUT VALVES)
-------	-------------------------

\* If you need the special specification.  
 Please contact us.

### PORT SIZE

X	PORTS		
	1,2	3	
<b>G04</b>	G 1/2"	G 1/2"	
<b>S08</b>	SAE 8	SAE 8	
<b>S10</b>	SAE 10	SAE 10	

### Y BODY MATERIAL

**A** HIGH-STRENGTH ALUMINUM

**T** STEEL (black oxide)

### Z CARTRIDGE VALVES SELECTION

WITHOUT VALVE

**FR1L** FR10W31NL(13LPM,240bar)

**FR3L** FR10W33NL(38LPM,240bar)

Please refer to the list price of cartridge program.