

## SOLENOID OPERATED VALVE (Pilot Operated) (Poppet 2-Way Normally-Closed Cartridge Style With Extra Spring)

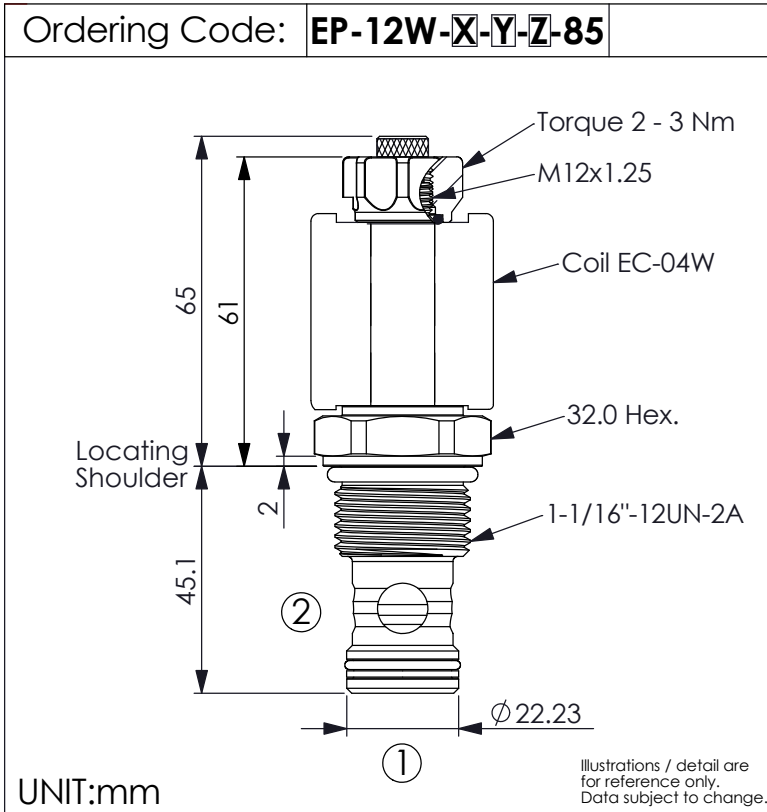

This design allows faster response times with very small flow or even virtually zero flow.

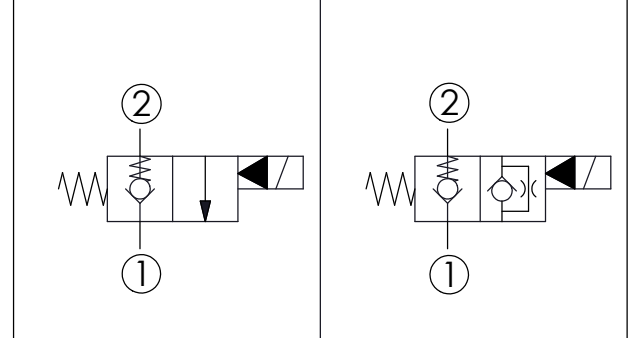

TECHNICAL DATA	
Max.Operating pressure:	350 bar
Rated flow:	150 l/min
Cavity-Tooling:	12W-2
Installation torque:	54 - 66 Nm
Weight:	0.230 (Z=N) kg

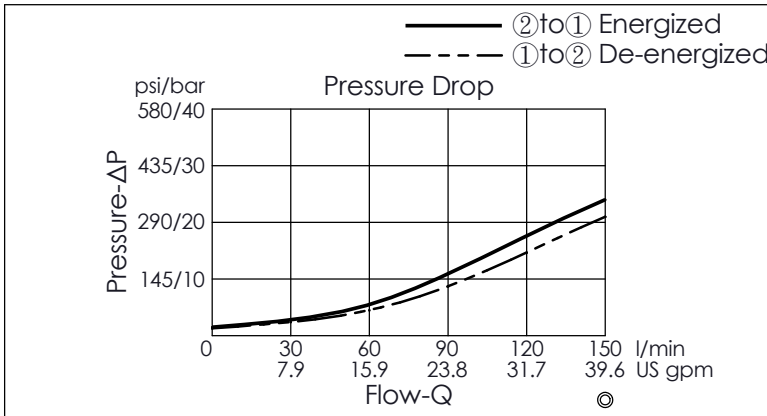

Internal Leakage Approximately:  
0.15 cc/minute  
(3 drops/minute) max. at 350 bar

Hydraulic Fluid Viscosity · Cleanliness · Temperature Level:  
Please refer WINNER technical information.  
( T.101.101.E HYDRAULIC FLUID (A) VISCOSITY )  
( T.101.102.E HYDRAULIC FLUID (B) CLEANLINESS )  
( T.101.103.E HYDRAULIC FLUID (C) TEMPERATURE )

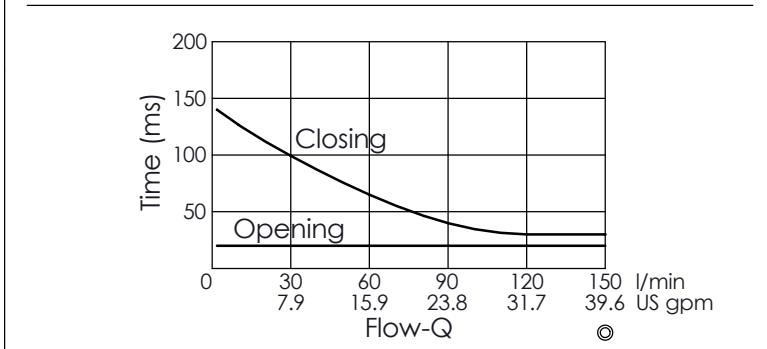

Minimum Voltage Required:  
90 % of nominal

Coils must be ordered separately

Mounting Position: unrestricted

The performance curve or data is only for reference, as customers' using condition, pressure, flow, hydraulic fluid viscosity, cleanliness, temperature and so on are different, the curve or data will be different.

X	STRUCTURE
2A	2 Ports · 20 Watt. Coil Ø 12.7 mm tube

Y	OPERATION
01	Normally-Closed No Reverse Flow Energized

This valve is similar to check valve when de- energized.  
Allow free flow from port ① to port ② and block flow from port ② to port ①.  
In energized condition, this valve is allowed flow from port ② to port ① but it's difficult to pass that flow from port ① to port ②.  
If you need bi-directional flow, please refer Y=05.

Z	OPTIONS
N	Non-adjustable
M	Screw-out Knob Style